

SCREW: SEE CHART	MATERIAL: NONE	REV: E	 800-776-9775 www.ilsco.com		
CAT. NO.: SEE CHART	PLATING: NONE	DRAWN BY: JG			SCALE: 1=1
INFORMATION SHEET: NONE	MARKING: NONE	DATE: 6/19/2015			SIZE: A
			DWG. NO. M2418-M2429 SHEET: 1 OF 1		

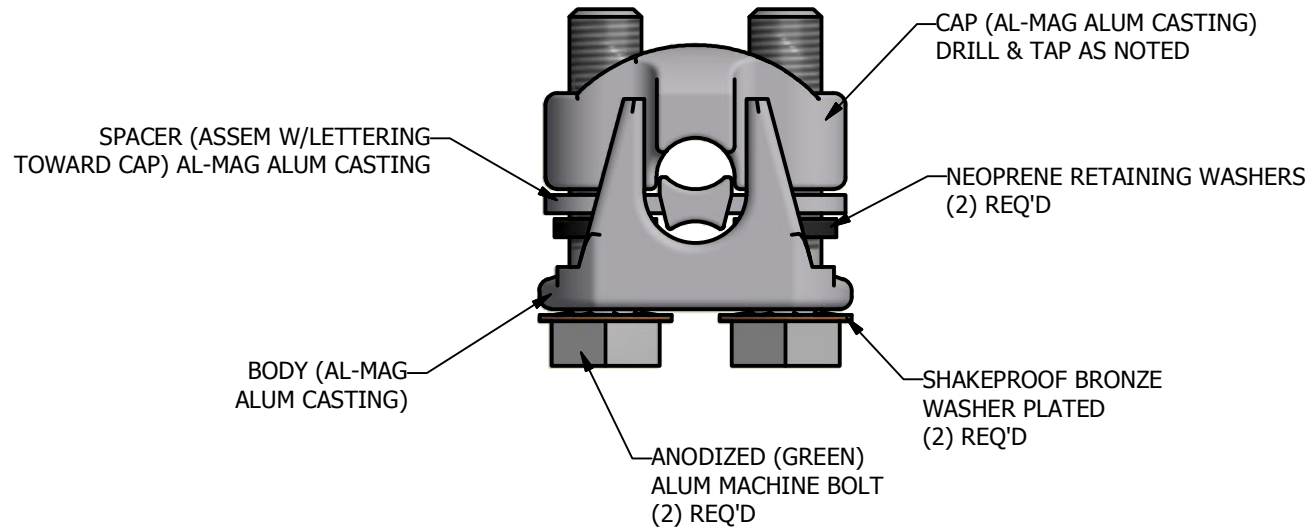

CAT #	BOLTS	DIA & THREAD	LENGTH	NEO WASHER	SHAKEPROOF WASHER	BODY	CAP	SPACER
DBA-2/0	E0432	3/8-24	1.625	E0439	E0473	K0011	K0021	NONE
DBA-2/0S	E0432	3/8-24	1.625	E0439	E0473	K0011	K0021	K0031
DBA-250	E0431	7/16-20	2.000	E0438	NONE	K0012	K0022	NONE
DBA-250S	E0431	7/16-20	2.000	E0438	NONE	K0012	K0022	K0032
DBA-350	E0430	1/2-20	2.250	E0437	NONE	K0013	K0023	NONE
DBA-350S	E0430	1/2-20	2.250	E0437	NONE	K0013	K0023	K0033
DBA-350SP	E0430	1/2-20	2.250	E0437	NONE	K0013	K0023	K0033
DBA-500	E0429	9/16-18	2.750	E0436	NONE	K0014	K0024	NONE
DBA-500S	E0429	9/16-18	2.750	E0436	NONE	K0014	K0024	K0034
DBA-500SP	(1) E0429, (1) E0433	9/16-18	2.750	E0436	NONE	K0014	K0024	K0034
DBA-800	E0433	9/16-18	3.000	E0436	NONE	K0015	K0025	NONE
DBA-800S	E0433	9/16-18	3.000	E0436	NONE	K0015	K0025	K0035
DBA-1000	E0434	5/8-18	3.500	E0435	NONE	K0016	K0026	NONE
DBA-1000S	E0434	5/8-18	3.500	E0435	NONE	K0016	K0026	K0036