

MASS:
CAT. NO.: CHARTED

TOLERANCES-UNLESS OTHERWISE SPECIFIED
2 PL. DEC. ±.010 TRUE C.L. ±.015
3 PL. DEC. ±.005 ANGLES ±1

DWG. NO. M2872
SHEET 1 OF 1
-02
-06
-04
-08



DRAWN BY: NN SCALE: 1/2
DATE: 6/10/2008 SIZE: A

REV.	DESCRIPTION

ASSEMBLY SPECIFICATIONS

PART NO.	CAP	COVER	BAR	CAT. NO.	SCREW	# OF OUTLETS	A
M2872A02A	R7146C00A	R1779C02A	N1294C02T	PCT-2-350	E1079C00T (2)	2	2.561
M2872A04A	R7146C00A	R1779C04A	N1294C04T	PCT-4-350	E1079C00T (4)	4	4.873
M2872A06A	R7146C00A	R1779C06A	N1294C06T	PCT-6-350	E1079C00T (6)	6	7.185
M2872A08A	R7146C00A	R1779C08A	N1294C08T	PCT-8-350	E1079C00T (8)	8	9.497

CAT #: SEE CHART

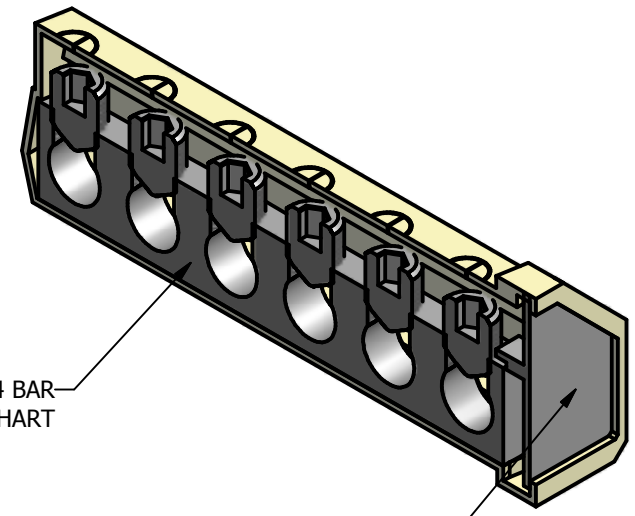
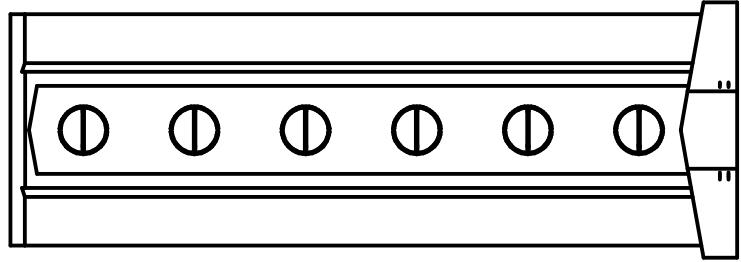

N1294 BAR
SEE CHART

MARKING ON R7145 END CAP
ILSCO CLEARTAP
PCT 350 AL9CU
350MCM-6
600V 90° 5/16" WRENCH
STRIP LENGTH

THE NUMBER OF OUTLETS-
TO BE INK MARKED OR
STAMPED IN THE SPACE PROVIDED

R1779 COVER
SEE CHART

