



► Model FB2PST and FB2PST-I

Fireball® Strobe Warning Light

Light duty strobe light

Federal Signal's brightest and most compact strobe light, the Fireball® emits a powerful "lightning bolt" flash of light. The Fireball is an economical solution to a wide variety of stationary and vehicular warning requirements. The Fireball is available in 12-24VDC, 24VDC, 120VAC and 240VAC. The FB2PST is available in five colors: Amber, Blue, Clear, Green and Red.

The 24VDC Model FB2PST-I features a voltage in-rush limiting PCB design that provides greater compatibility with factory automation control systems and less electrical interference with in-rush sensitive devices.

The Fireball features a unique dome that twists off easily for quick dome and lamp replacements. The base features an integrated 1/2-inch NPT pipe mount base as well as the three holes required for surface mount configurations. The Fireball dome and base design provides a water-tight, dust-tight and corrosion-resistant Type 4X rating.

The Fireball can be used in any application where a superior visual signal is needed. It is especially effective in industrial hazard warning, process control, status indication and in areas with high ambient noise levels.

Federal Signal's Fireball strobe is a very low-maintenance warning light for industrial applications where a vibration-resistant light is required to signal an emergency or process status.

FEATURES

- Available in 12-24VDC, 120VAC and 240VAC
- Five dome colors: Amber, Blue, Clear, Green and Red
- 10,000 hour strobe tube
- Integrated 1/2-inch NPT pipe and surface mount
- Indoor/outdoor use
- Type 4X, IP66 enclosure
- UL and cUL Listed and CSA Certified

MODEL	VOLTAGE	OPERATING CURRENT	FLASH RATE/ MINUTE	CANDELA		MOUNT
				PEAK ¹	ECP ²	
FB2PST-012-024 *	12-24VDC	1.70-0.70 amps	80	1,000,000	300	1/2" NPT Pipe/Surface
FB2PST-I-024 *	24VDC	0.70 amps (2.0 amp In-rush)	80	1,000,000	300	1/2" NPT Pipe/Surface
FB2PST-120 *	120VAC 50/60Hz	0.25 amps	90	1,000,000	300	1/2" NPT Pipe/Surface
FB2PST- 240 *	240VAC 50/60Hz	0.20 amps	90	1,000,000	300	1/2" NPT Pipe/Surface

* Indicates color: (A) Amber, (B) Blue, (C) Clear, (G) Green or (R) Red

¹ Peak candela is the maximum light intensity generated by a flashing light during its light pulse

² ECP (Effective Candela) is the intensity that would appear to an observer if the light were burning steadily

Fireball® Strobe Warning Light (FB2PST / FB2PST-I)

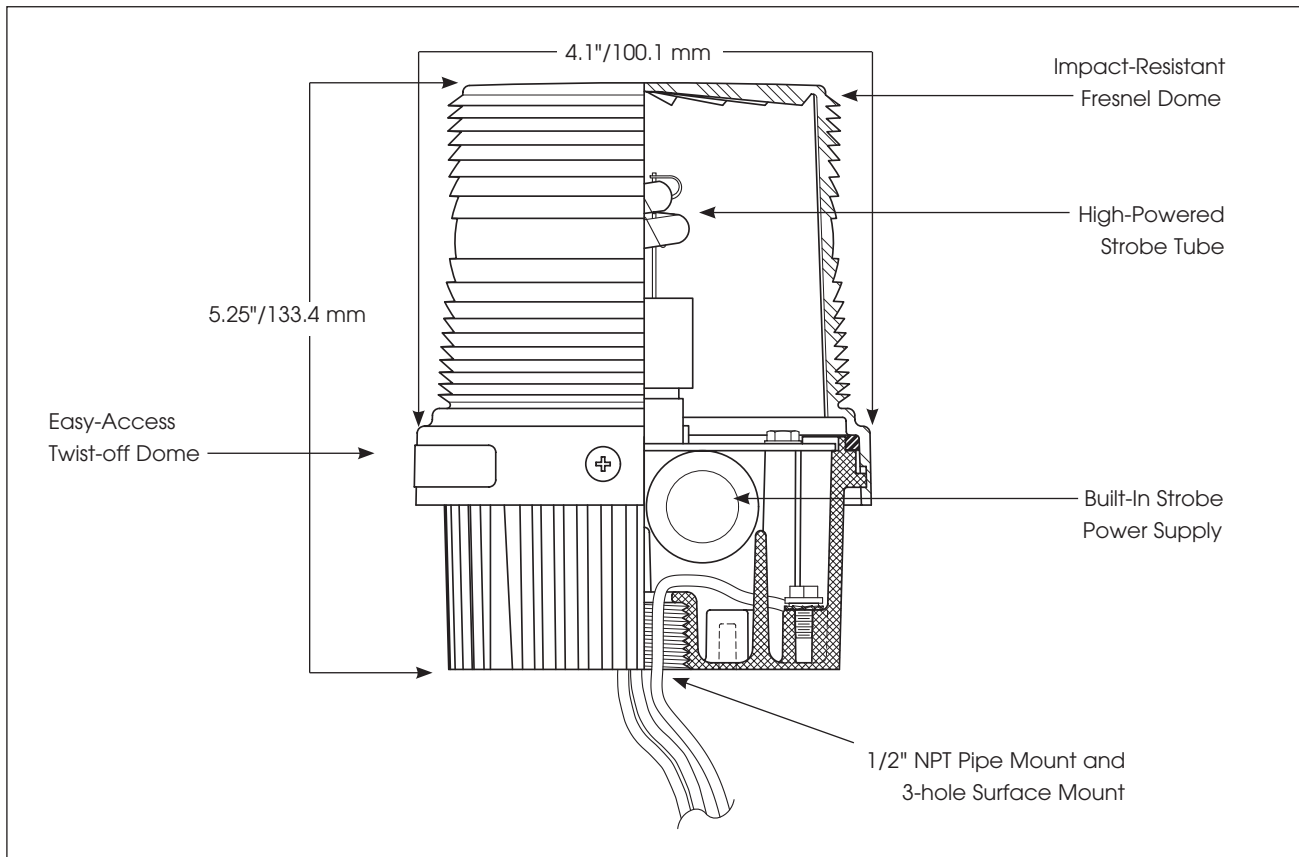

SPECIFICATIONS

Lamp Life:	10,000 Hours	10,000 Hours
Light Source:	Strobe tube	Strobe tube
Operating Temperature:	-31°F to 150°F	-35°C to 66°C
Net Weight:	2.0 lbs.	0.9 kg
Shipping Weight:	2.12 lbs.	0.96 kg
Height:	5.25"	133.4 mm
Diameter:	4.10"	100.1 mm

REPLACEMENT PARTS

Description	Part Number
Dome, Amber	K8550320A
Dome, Blue	K8550320A-01
Dome, Clear	K8550320A-02
Dome, Green	K8550320A-03
Dome, Magenta	K8550320A-05
Dome, Red	K8550320A-04
PC Assembly, 120VAC	K200D866G
PC Assembly, 240VAC	K200D866G-01
Strobe Tube, Series A4, A5, B	K8107177A

HOW TO ORDER

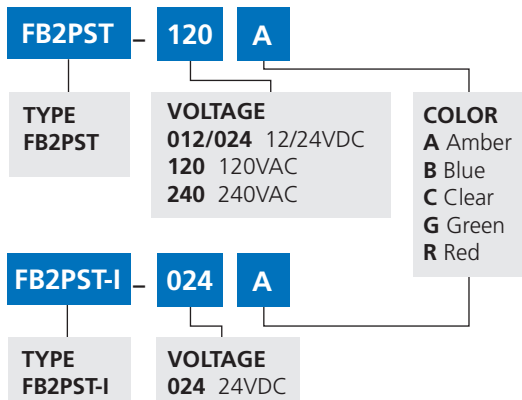

OPTIONAL ACCESSORIES

Description	Part Number
Corner Bracket	LCMB2*
Wall Bracket	LWMB2*
Hazardous Location Mounting Bracket	LHWB

*Not Type 4X rated.

