

SCREW: SEE CHART	MATERIAL: NONE	REV: I	 800-776-9775 www.ilsco.com		
CAT. NO.: IPC-500-250 & IPC-500-250-B	PLATING: NONE	DRAWN BY: JG			SCALE: 1=1
INFORMATION SHEET: FORM 71	MARKING: NONE	DATE: 2/4/2008			SIZE: A
			DWG. NO.	<b>K0426</b>	
			SHEET: 1 OF 1		

DESCRIPTION	IPC-500-250 K0426W00TI		IPC-500-250-B K0426W01TI	
	COMPONENT	QTY/EA	COMPONENT	QTY/EA
MOLDED BODY (TOP AND BOTTOM)	130135	1	130135	1
TOP PLATE (ZN PLATED)	130110	1	130110	1
TEETH (SN PLATED/BRBD)	130079	4	130079	4
BOTTOM PLATE (ZN PLATED/CHAMPHER/DRILLED)	130087	1	130087	1
RUN LABEL	100148	1	100148	1
TAP LABEL	100149	1	100149	1
BOLT M10 X 1.5 X 3.8 (REF)	130103	1	130103	1
NUT - HEX HEAD	410210	1	410210	1
WASHER	130114	1	130114	1
BOX	100369	.25	CCR0512	.5
PLASTIC BAG			CBR1427	1

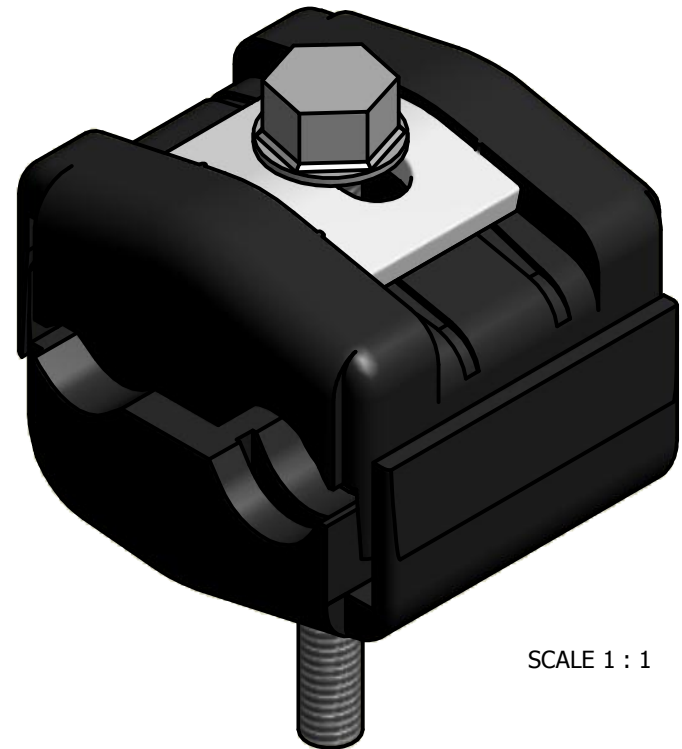

SCALE 1 : 1