

# DUAL TECHNOLOGY DUAL RELAY WALL SWITCH OCCUPANCY SENSOR

| DW-200

High sensitivity and dense coverage  
for exceptional performance

Two relays for control of two  
separate lighting loads or circuits

Color-matched lens and low  
profile for appealing design



Selectable operation, walk-through, test  
and presentation modes for increased  
energy savings and convenience

Defaults to Auto-ON to 50% operation  
for maximum energy savings

## Description

The DW-200 dual technology wall switch sensor combines the benefits of passive infrared (PIR) and ultrasonic technologies to turn lights ON and OFF based on occupancy. It contains two relays for controlling two independent lighting loads or circuits and a variety of features.

## Operation

The DW-200 fits in a single gang junction box. Each of the DW-200's relays can control a separate lighting load. By default, when both PIR and ultrasonic technologies detect occupancy, relay 1 turns ON automatically. Detection by either technology holds lights ON. When occupancy is no longer detected and the time delay elapses, lights automatically turn OFF. Dual ON/OFF buttons allow the user to manually turn on and off each of the loads. DIP switch settings allow for a variety of control options such as Auto-ON or Manual-ON for each relay, walk-through, and test mode.

## Features

- Complies with 2011 NEC requirements
- Detection Signature Processing eliminates false triggers and provides immunity to RFI and EMI
- Zero-crossing on both relays for long relay life
- Vandal resistant lens combines precise coverage with durability
- Choice of Manual-ON or Auto-ON operation, selectable for each relay
- Selectable walk-through mode turns lights off three minutes after the room is initially occupied if no motion is detected after the first 30 seconds
- Test mode allows quick and easy adjustments
- Selectable audible alert for impending shutoff
- In automatic mode, sensor returns automatically to Auto-ON after lights are turned off manually; ideal for presentations
- Four occupancy logic options give users the ability to customize control to meet application needs
- Optional light level sensing with simple setup
- Service mode allows sensor to operate as a service switch in the unlikely event of a failure
- Sensor coverage tested to NEMA Guide Publication WD 7-2000
- Compatible with decorator wall plates
- BAA/TAA-compliant models available

## Bi-Level Control

The DW-200 features a built-in light level sensor that controls the second (secondary) relay. If adequate daylight is present, the sensor will hold secondary lights off until daylight levels drop, providing increased energy savings. The DW-200 satisfies energy codes requiring bi-level or daylight control switching. The two relays in the sensor give it the ability to control two lighting loads independently. This provides A/B switching where the user can achieve half-lighting (or another desired portion) from a single switch.

## Applications

The DW-200 has the flexibility for applications where one technology alone may not be sufficient. In addition, its dual relays allow bi-level switching or control of two loads. Applications include small and executive offices, small and medium conference rooms and lunch/break rooms. This sensor is also a perfect choice for ADA-compliant buildings due to lower mounting height requirements.

PROJECT		LOCATION/ TYPE	
---------	--	-------------------	--

## Specifications

- 120/277 VAC; 50/60 Hz  
@ 120 VAC, 0-800 W ballast or tungsten, 1/6 hp  
@ 277 VAC, 0-1200 W ballast
- Time delays: 5, 15 or 30 minutes, walk-through, test-mode
- Coverage:  
Major motion, PIR 35' x 30', Ultrasonic 20' x 20'  
Minor motion, PIR 20' x 15', Ultrasonic 15' x 15'
- Sensitivity adjustment: PIR (high/low), Ultrasonic (fully variable)
- Dimensions: 2.73" x 1.76" x 1.83"  
(69.3mm x 44.7mm x 46.5mm) L x W x D
- UL and cUL listed
- Five year warranty

## Controls & Settings

### Product Controls

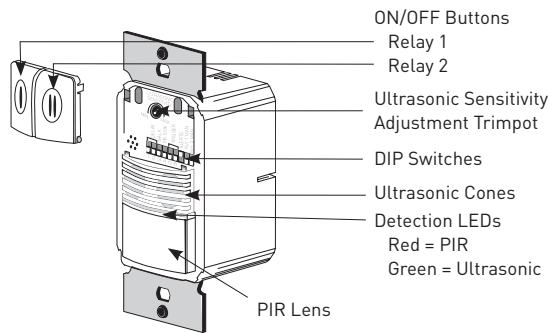

### DIP Switch Settings

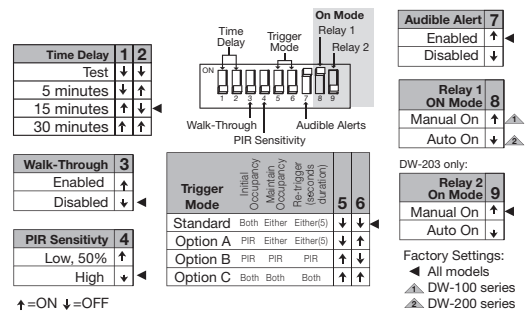

## Coverage & Wiring

### Coverage Pattern

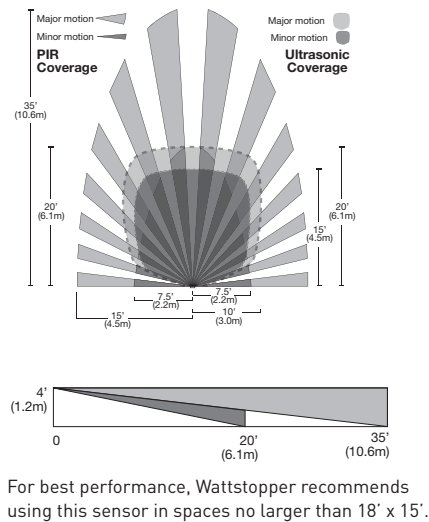

### Wiring Diagrams

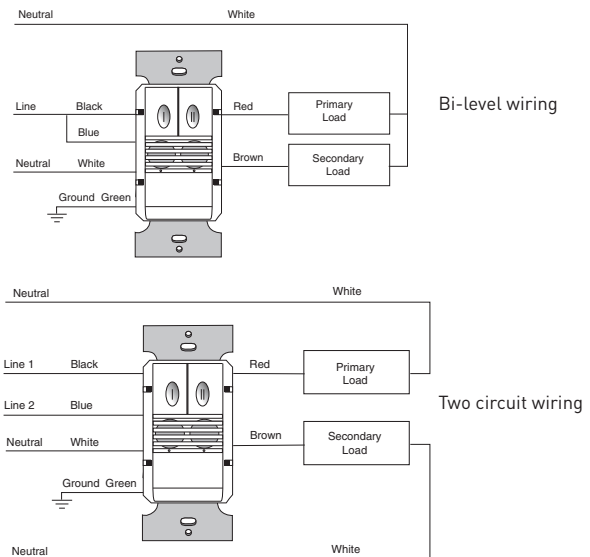

## Ordering Information

Catalog #	Color	Voltage	Load Rating
<input type="checkbox"/> DW-200-W	White	1120/277 VAC; 50/60 Hz	@ 120 VAC, 0-800 W ballast or tungsten, 1/6 hp @ 277 VAC 0-1200 W ballast
<input type="checkbox"/> DW-200-W-U			
<input type="checkbox"/> DW-200-LA	Lt. Almond		
<input type="checkbox"/> DW-200-I	Ivory		
<input type="checkbox"/> DW-200-I-U			
<input type="checkbox"/> DW-200-G	Grey		
<input type="checkbox"/> DW-200-B	Black		

Order wall plate separately.

-U = BAA/TAA compliant; product is compliant with Buy American Act and Trade Agreement Act.