



F-can (72C)

F-CAN HID 72C5181NP001

The Philips Advance line of F-can HID ballasts comes in two dual-voltage configurations for the US and Canadian market. Ballasts for these luminaires are most often encased and potted in fluorescent ballast type cans.

Product data

General Information	
ANSI Code	M110(PULSESTART)
Lamp Type	50W MH
Number Of Lamps	1 piece/unit
Circuit Type	HX-HPF
Ballast Type	Magnetic HID
Base Model	72C5181
Suitable For Outdoor Use	Yes
Ignitor Catalog Number	Inside Can
Capacitor Catalog Number	Inside Can
Automatic Restart	No
Operating and Electrical	
Input Voltage	120/277 V
Input Frequency	60 Hz
Power (Rated) (Nom)	50 W
Input Current (Open Circuit)	1.15/0.5 A
Input Current (Starting)	0.8/0.35 A
Input Current (Short Circuit)	0.25-0.45/0.1-0.2 A
Secondary Short Circuit Current	0.7-0.85 A
Constant Wattage Deviation	10%
Ballast Factor (Nom)	1
Power Factor (Nom)	0.90

Open Circuit Voltage	254 V
Input Current (Nom)	0.65/0.3 A A
Input Power (Nom)	72 W
Rated Lamp Power	50W W
Wiring	
Wire Striplength	0.5 mm
Wire Length By Color	12"
Wire Type	Stranded
Remote Wiring Configuration Allowed	Yes
Max Ballast-Lamp Distance Remote Wiring	25'
Recommended Fuse Value	3/2 A
Mechanical and Housing	
Housing Material	Metal
Housing	F-Can
Housing Dimensions	11.75 x 2.63 x 3.19
Approval and Application	
Open Circuit Voltage Test (Volts)	230-280 V
Temperature Marking	90°C max. case
UL Recognized	No
Hipot Test (1 Minute)	1600 V

F-can (72C)

Hipot Test (2 Seconds)	2000 V
UL Insulation Class	A(105°C)
UL Temperature Code	NA
Product Data	
Order product name	F-CAN HID 72C5181NP001
EAN/UPC - Product	781087025192

Order code	913710407301
Numerator - Quantity Per Pack	1
Numerator - Packs per outer box	1
Material Nr. (12NC)	913710407301
Net Weight (Piece)	3.498 kg

Dimensional drawing

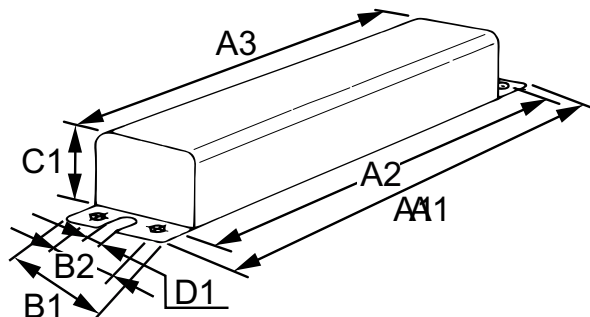

MH BAL 50W M110 120/277V FCAN

Product	A1	A2	A3	B1	B2	C1	D1
---------	----	----	----	----	----	----	----

