

SIEMENS

SIMATIC NET

Industrial Ethernet switches SCALANCE XB-100

Operating Instructions

<u>Introduction</u>	1
<u>Safety notices</u>	2
<u>Description of the device</u>	3
<u>Installation</u>	4
<u>Connecting up</u>	5
<u>Upkeep and maintenance</u>	6
<u>Technical specifications</u>	7
<u>Dimension drawings</u>	8
<u>Approvals</u>	A

Legal information

Warning notice system

This manual contains notices you have to observe in order to ensure your personal safety, as well as to prevent damage to property. The notices referring to your personal safety are highlighted in the manual by a safety alert symbol, notices referring only to property damage have no safety alert symbol. These notices shown below are graded according to the degree of danger.

! DANGER
indicates that death or severe personal injury will result if proper precautions are not taken.

! WARNING
indicates that death or severe personal injury may result if proper precautions are not taken.

! CAUTION
indicates that minor personal injury can result if proper precautions are not taken.

NOTICE
indicates that property damage can result if proper precautions are not taken.

If more than one degree of danger is present, the warning notice representing the highest degree of danger will be used. A notice warning of injury to persons with a safety alert symbol may also include a warning relating to property damage.

Qualified Personnel

The product/system described in this documentation may be operated only by **personnel qualified** for the specific task in accordance with the relevant documentation, in particular its warning notices and safety instructions. Qualified personnel are those who, based on their training and experience, are capable of identifying risks and avoiding potential hazards when working with these products/systems.

Proper use of Siemens products

Note the following:

! WARNING
Siemens products may only be used for the applications described in the catalog and in the relevant technical documentation. If products and components from other manufacturers are used, these must be recommended or approved by Siemens. Proper transport, storage, installation, assembly, commissioning, operation and maintenance are required to ensure that the products operate safely and without any problems. The permissible ambient conditions must be complied with. The information in the relevant documentation must be observed.

Trademarks

All names identified by ® are registered trademarks of Siemens AG. The remaining trademarks in this publication may be trademarks whose use by third parties for their own purposes could violate the rights of the owner.

Disclaimer of Liability

We have reviewed the contents of this publication to ensure consistency with the hardware and software described. Since variance cannot be precluded entirely, we cannot guarantee full consistency. However, the information in this publication is reviewed regularly and any necessary corrections are included in subsequent editions.

Table of contents

1	Introduction	5
2	Safety notices	9
3	Description of the device	11
3.1	Properties and functions	11
3.2	Product overview.....	11
3.2.1	Accessories.....	12
3.2.2	Spare parts.....	13
3.3	Device views	13
3.3.1	Device view of a SCALANCE XB108-2.....	13
3.3.2	Device view of a SCALANCE XB112.....	14
3.3.3	Device view of a SCALANCE XB116.....	14
3.3.4	Device view of a SCALANCE XB124.....	15
3.4	LED display.....	15
4	Installation	17
4.1	Safety notices for installation	17
4.2	Mounting on DIN rails.....	20
5	Connecting up	23
5.1	Safety when connecting up.....	23
5.2	Industrial Ethernet.....	24
5.2.1	Electrical.....	24
5.2.2	Optical.....	26
5.3	Wiring rules	27
5.4	Power supply.....	28
5.5	Functional ground	29
6	Upkeep and maintenance	31
7	Technical specifications	33
7.1	Technical specifications of the SCALANCE XB108-2(SC)	33
7.2	Technical specifications of the SCALANCE XB108-2(ST).....	34
7.3	Technical specifications of the SCALANCE XB112	36
7.4	Technical specifications of the SCALANCE XB116	37
7.5	Technical specifications of the SCALANCE XB124	38
7.6	Cable lengths	39
7.7	Switching properties.....	39

Table of contents

8	Dimension drawings	41
A	Approvals.....	45
	Index.....	53

Introduction

Purpose of the Operating Instructions

These operating instructions support you when installing and connecting up devices of the SCALANCE XB-100 product group.

The configuration and the integration of the devices in a network are not described in these operating instructions.

Validity of the Operating Instructions

These operating instructions apply to the following devices:

- SCALANCE XB108-2(SC)
- SCALANCE XB108-2(ST)
- SCALANCE XB112
- SCALANCE XB116
- SCALANCE XB124

Unless mentioned otherwise, the descriptions in these operating instructions refer to all devices of the SCALANCE XB-100 product group named in the section on validity.

Designations used

Classification	Description	Terms used
Product line	The product line includes all devices and variants of all product groups. If information applies to all product groups within the product line, the term SCALANCE X-100 is used.	SCALANCE X-100
Product group	If information applies to all devices and variants of a product group, the term SCALANCE XB-100 is used.	SCALANCE XB-100
Device	If information relates to a specific device, the device name is used.	e.g. SCALANCE XB108-2(ST)

Further documentation

In the system manuals "Industrial Ethernet / PROFINET Industrial Ethernet" and "Industrial Ethernet / PROFINET passive network components", you will find information on other SIMATIC NET products that you can operate along with the devices of this product line in an Industrial Ethernet network.

There, you will find among other things optical performance data of the communications partner that you require for the installation.

You will find the system manuals here:

- On the data medium that ships with some products:
 - Product CD / product DVD
 - SIMATIC NET Manual Collection
- On the Internet pages of Siemens Industry Online Support:
 - Industrial Ethernet / PROFINET Industrial Ethernet System Manual (<https://support.industry.siemens.com/cs/ww/en/view/27069465>)
 - Industrial Ethernet / PROFINET Passive Network Components System Manual (<https://support.industry.siemens.com/cs/ww/en/view/84922825>)

SIMATIC NET manuals

You will find the SIMATIC NET manuals here:

- On the data medium that ships with some products:
 - Product CD / product DVD
 - SIMATIC NET Manual Collection
- On the Internet pages of Siemens Industry Online Support (<https://support.industry.siemens.com/cs/ww/en/ps/15247>).

SIMATIC NET glossary

Explanations of many of the specialist terms used in this documentation can be found in the SIMATIC NET glossary.

You will find the SIMATIC NET glossary here:

- SIMATIC NET Manual Collection or product DVD
The DVD ships with certain SIMATIC NET products.
- On the Internet under the following address:
50305045 (<https://support.industry.siemens.com/cs/ww/en/view/50305045>)

Security information

Siemens provides products and solutions with industrial security functions that support the secure operation of plants, systems, machines and networks.

In order to protect plants, systems, machines and networks against cyber threats, it is necessary to implement – and continuously maintain – a holistic, state-of-the-art industrial security concept. Siemens' products and solutions constitute one element of such a concept.

Customers are responsible for preventing unauthorized access to their plants, systems, machines and networks. Such systems, machines and components should only be connected to an enterprise network or the internet if and to the extent such a connection is necessary and only when appropriate security measures (e.g. firewalls and/or network segmentation) are in place.

For additional information on industrial security measures that may be implemented, please visit

<https://www.siemens.com/industrialsecurity> (<https://www.siemens.com/industrialsecurity>)

Siemens' products and solutions undergo continuous development to make them more secure. Siemens strongly recommends that product updates are applied as soon as they are available and that the latest product versions are used. Use of product versions that are no longer supported, and failure to apply the latest updates may increase customers' exposure to cyber threats.

To stay informed about product updates, subscribe to the Siemens Industrial Security RSS Feed under

<https://www.siemens.com/industrialsecurity> (<https://www.siemens.com/industrialsecurity>)

Catalogs

You will find the article numbers for the Siemens products of relevance here in the following catalogs:

- SIMATIC NET Industrial Communication / Industrial Identification, catalog IK PI
- SIMATIC Products for Totally Integrated Automation and Micro Automation, catalog ST 70
- Industry Mall - catalog and ordering system for automation and drive technology, Online catalog (<https://mall.industry.siemens.com/goos/WelcomePage.aspx?regionUrl=/en&language=en>)

You can request the catalogs and additional information from your Siemens representative.

Device defective

If a fault develops, please send the device to your SIEMENS service center for repair. Repairs on-site are not possible.

Recycling and disposal



The products are low in pollutants, can be recycled and meet the requirements of the WEEE directive 2012/19/EU for the disposal of electrical and electronic equipment.

Do not dispose of the products at public disposal sites.

For environmentally friendly recycling and the disposal of your old device contact a certified disposal company for electronic scrap or your Siemens contact (Product return (<https://support.industry.siemens.com/cs/ww/en/view/109479891>)).

Note the different national regulations.

Trademarks

The following and possibly other names not identified by the registered trademark sign ® are registered trademarks of Siemens AG:

SIMATIC NET, SCALANCE, C-PLUG, OLM

Safety notices

Read the safety notices

Note the following safety notices. These relate to the entire working life of the device.

You should also read the safety notices relating to handling in the individual sections, particularly in the sections "Installation" and "Connecting up".

 CAUTION
To prevent injury, read the manual before use.

Safety notices on use in hazardous areas

General safety notices relating to protection against explosion

 WARNING
EXPLOSION HAZARD
Do not open the device when the supply voltage is turned on.

Safety notices when using the device according to Hazardous Locations (HazLoc) and FM.

If you use the device under HazLoc or FM conditions you must also keep to the following safety notices in addition to the general safety notices for protection against explosion:

This equipment is suitable for use in Class I, Division 2, Groups A, B, C and D or non-hazardous locations only.

This equipment is suitable for use in Class I, Zone 2, Group IIC or non-hazardous locations only.

Description of the device

3.1 Properties and functions

The SCALANCE XB-100 is an unmanaged Industrial Ethernet- switch with a compact plastic enclosure. The different versions have electrical and/or optical interfaces. All version are PROFINET CC-A compliant and can be used in hazardous areas of Zone 2.

Due to the flexible power supply, the IE switches SCALANCE XB-100 are suitable for use in the industry (24 V DC) and building technology (24 V AC).

3.2 Product overview

Article numbers

Device	Description	Article number
SCALANCE XB108-2(SC)	8 x 10/100 Mbps RJ45 ports, 2 x 10/100 Mbps SC ports, multimode fiber-optic cable	6GK5 108-2BD00-2AB2
SCALANCE XB108-2(ST)	8 x 10/100 Mbps RJ45 ports, 2 x 10/100 Mbps ST/BFOC ports, multimode fiber-optic cable	6GK5 108-2BB00-2AB2
SCALANCE XB112	12 x 10/100 Mbps RJ45 ports	6GK5 112-0BA00-2AB2
SCALANCE XB116	16 x 10/100 Mbps RJ45 ports	6GK5 116-0BA00-2AB2
SCALANCE XB124	24 x 10/100 Mbps RJ45 ports	6GK5 124-0BA00-2AB2

Type designation

The type designation of a SCALANCE XB-100 is made up of several parts that have the following meaning:

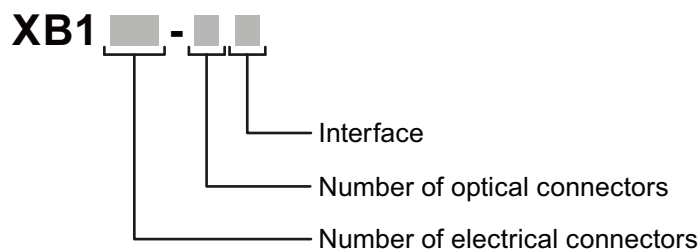

Interfaces of devices with optical connectors:

Interface	Property
SC	10/100 Mbps SC port, multimode fiber-optic cable, up to 5 km
ST	10/100 Mbps ST/BFOC port, multimode fiber-optic cable, up to 5 km

Unpacking and checking

 WARNING
Do not use any parts that show evidence of damage
If you use damaged parts, there is no guarantee that the device will function according to the specification.
If you use damaged parts, this can lead to the following problems:
<ul style="list-style-type: none">• Injury to persons• Loss of the approvals• Violation of the EMC regulations• Damage to the device and other components
Use only undamaged parts.

1. Make sure that the package is complete.
2. Check all the parts for transport damage.

Components of the product

The following components are supplied with a SCALANCE XB-100:

- One IE switch
- Two 3-terminal blocks for the power supply

3.2.1 Accessories

Accessories

The following accessories are available for SCALANCE XB-100:

Power supply

Component	Description	Article number
SITOP PSU100C 24V/0.6 V	Stabilized power supply Input: 1-phase 100-240 V AC or 110-300 V DC Output: 24 V DC/0.6 A	6EP1 331-5BA00
LOGO!Power 24 V/1.3 A	Stabilized power supply Input: 1-phase 100-240 V AC or 110-300 V DC Output: 24 V DC/1.3 A	6EP1 331-1SH03

You will find additional accessories in the Industry Mall (<https://eb.automation.siemens.com/goos/WelcomePage.aspx?regionUrl=/en&language=en>).

3.2.2 Spare parts

Spare parts

The following spare parts are available for SCALANCE XB-100:

Component	Description	Article number
Spring-loaded terminal block, 3-pole	3-pole spring-loaded terminal block to connect the power supply (24 V AC/DC), pack of 5	6GK5 980-1CB10-0CA5

3.3 Device views

3.3.1 Device view of a SCALANCE XB108-2

The following figure shows an overview of the components of the SCALANCE XB108-2 using the SCALANCE XB108-2(SC) as an example. The SCALANCE XB108-2(ST) only differs in the optical interfaces.

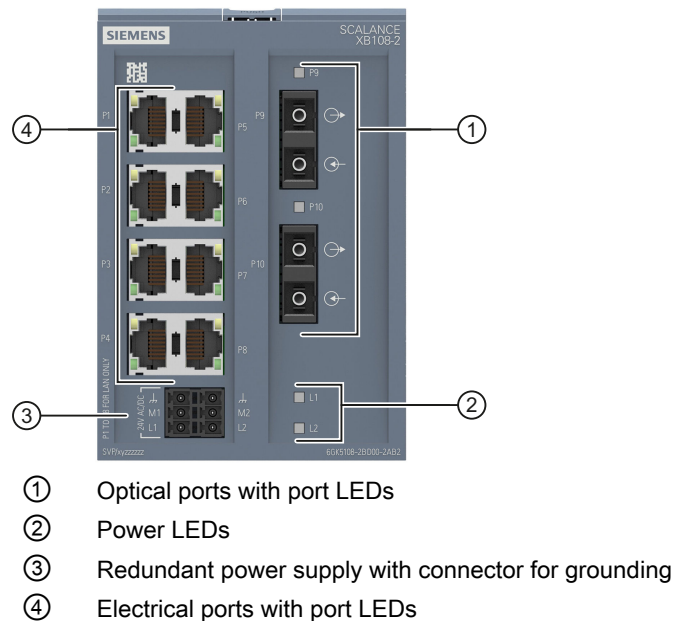

3.3.2 Device view of a SCALANCE XB112

The following figure shows an overview of the components of the SCALANCE XB112.

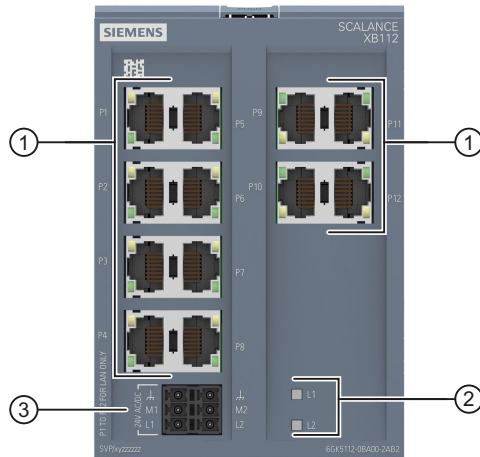

- ① Electrical ports with port LEDs
- ② Power LEDs
- ③ Redundant power supply with connector for grounding

3.3.3 Device view of a SCALANCE XB116

The following figure shows an overview of the components of the SCALANCE XB116.

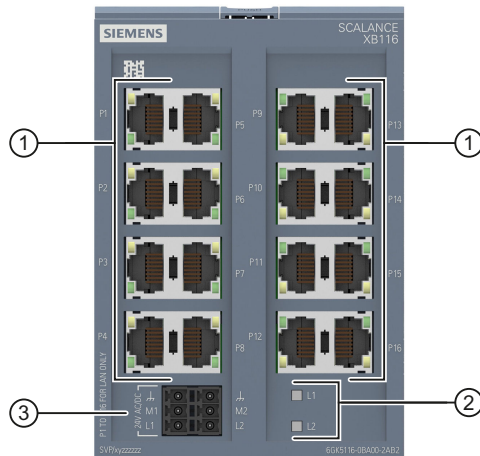

- ① Electrical ports with port LEDs
- ② Power LEDs
- ③ Redundant power supply with connector for grounding

3.3.4 Device view of a SCALANCE XB124

The following figure shows an overview of the components of the SCALANCE XB124.

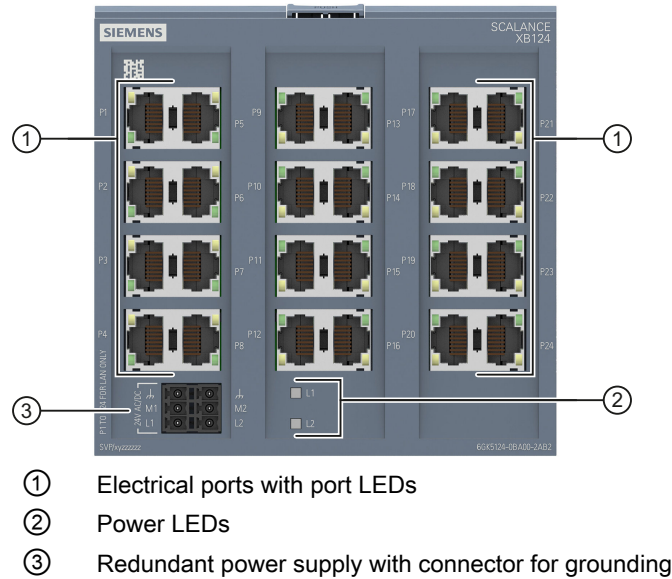

3.4 LED display

Port LEDs "P"

The port LEDs indicate the status of the ports.

RJ-45 ports

Each RJ-45 port has 2 integrated LEDs.

The green LED shows the status of the link.

LED color	LED status	Meaning
Green	Lit	link exists
-	Off	No link exists

The yellow LED shows the status of data reception.

LED color	LED status	Meaning
Yellow	Flashing	Receiving data at port
-	Off	Not receiving data at port

3.4 LED display

SC/ST ports

There is an LED for each SC/ST port.

LED color	LED status	Meaning
Green	Lit	link exists
Orange	Lit	Receiving data at port
-	Off	No link exists

Power LEDs "L1" and "L2" (green LEDs)

The power LEDs show the status of the power supply at connectors L1 and L2.

LED color	LED status	Meaning
Green	Lit	Power supply L1 or L2 is connected.
-	Off	Power supply L1 and L2 are not connected or L1 and L2 <9.6 V.

Installation

4.1 Safety notices for installation

Safety notices

When installing the device, keep to the safety notices listed below.

 **WARNING**

If a device is operated in an ambient temperature of more than 50 °C, the temperature of the device housing may be higher than 70 °C. The device must therefore be installed so that it is only accessible to service personnel or users that are aware of the reason for restricted access and the required safety measures at an ambient temperature higher than 50 °C.

 **WARNING**

If the device is installed in a cabinet, the inner temperature of the cabinet corresponds to the ambient temperature of the device.

Safety notices on use in hazardous areas

General safety notices relating to protection against explosion

 **WARNING**

EXPLOSION HAZARD

Replacing components may impair suitability for Class 1, Division 2 or Zone 2.

 **WARNING**

The device is intended for indoor use only.

 **WARNING**

The device may only be operated in an environment of pollution degree class 2 (cf. IEC 60664-1).

4.1 Safety notices for installation

 WARNING
When used in hazardous environments corresponding to Class I, Division 2 or Class I, Zone 2, the device must be installed in a cabinet or a suitable enclosure.

Safety notices for use according to ATEX and IECEx

If you use the device under ATEX or IECEx conditions you must also keep to the following safety notices in addition to the general safety notices for protection against explosion:

 WARNING
The equipment shall only be used in an area of not more than pollution degree 2, as defined in EN/IEC 60664-1.

 WARNING
Requirements for the cabinet/enclosure
The equipment shall be installed in a suitable enclosure that provides a degree of protection not less than IP54 in accordance with EN/IEC 60079-15.

 WARNING
If the cable or conduit entry point exceeds 70 °C or the branching point of conductors exceeds 80 °C, special precautions must be taken. If the equipment is operated in an air ambient in excess of 60 °C, only use cables with admitted maximum operating temperature of at least 80 °C.

Safety notices when using according to FM

If you use the device under FM conditions you must also keep to the following safety notices in addition to the general safety notices for protection against explosion:

 WARNING
EXPLOSION HAZARD
The equipment is intended to be installed within an enclosure/control cabinet. The inner service temperature of the enclosure/control cabinet corresponds to the ambient temperature of the module. Use cables with a maximum permitted operating temperature of at least 20 °C higher than the maximum ambient temperature.

 WARNING
Wall mounting outside of the control cabinet or housing does not fulfill the requirements of the FM approval.

⚠ WARNING

Wall mounting is only permitted if the requirements for the housing, the installation regulations, the clearance and separating regulations for the control cabinets or housings are adhered to. The control cabinet cover or housing must be secured so that it can only be opened with a tool. An appropriate strain-relief assembly for the cable must be used.

Note

You must not install the device on a wall in hazardous areas.

Safety notices when using the device as industrial control equipment according to UL 61010-2-201

If you use the device under UL 61010-2-201 conditions you must also keep to the following safety notices in addition to the general safety notices for protection against explosion:

⚠ WARNING

The devices are "open equipment" acc. to the standard UL 61010-2-201. To fulfill requirements for safe operation with regard to mechanical stability, flame retardation, stability, and protection against contact, the following alternative types of installation are specified:

- Installation in a suitable cabinet.
- Installation in a suitable enclosure.
- Installation in a suitably equipped, enclosed control room.

⚠ WARNING

If the cable or housing socket exceeds 70 °C or the branching point of the cables exceeds 60 °C, special precautions must be taken. If the equipment is operated in an air ambient in excess of 40 °C, only use cables with admitted maximum operating temperature of at least 80 °C.

Devices with approval [op is Gb] for optical interfaces

Some devices have an additional ATEX approval according to II 3 (2) G Ex nA [op is Gb] IIC T4 Gc and an additional approval in compliance with IECEx according to Ex nA [op is Gb] IIC T4 Gc, see section "Approvals (Page 45)". This is indicated on the type plate. With these devices the FO bus connections may run through or in a Zone 1 hazardous area.

Further notes

 CAUTION
Use only approved components If you use components and accessories that are not approved for SIMATIC NET devices or their target systems, this may violate the requirements and regulations for safety and electromagnetic compatibility. Only use components approved for the SIMATIC NET devices.

NOTICE
Warming and premature aging of the IE switch due to direct sunlight Direct sunlight can heat up the device and can lead to premature aging of the IE switch and its cabling. Provide suitable shade to protect the IE switch against direct sunlight.

Note

During installation and operation, keep to the installation guidelines and safety notices described in this document and in the system manuals "Industrial Ethernet / PROFINET Industrial Ethernet" and "Industrial Ethernet / PROFINET passive network components".

You will find information on the system manuals in the chapter "Introduction", in the section "Further documentation".

4.2 Mounting on DIN rails

Installation clearances

Keep to the following minimum clearances so that the convection ventilation of the device is not blocked:

- Below at least 10 cm
- Above at least 10 cm

Installation

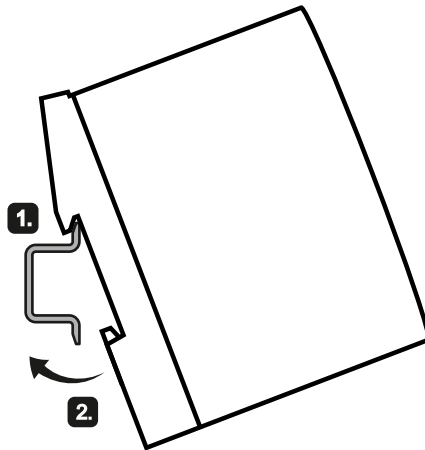

Figure 4-1 DIN rail mounting

To install the device on a 35 mm DIN rail complying with DIN EN 60715, follow the steps below:

1. Place the housing guide of the device on the top edge of the DIN rail ①.
2. Press the device down against the DIN rail until the spring catch locks in place ②.
3. Fit the connectors for the power supply, see the section "Power supply (Page 28)".
4. Insert the terminal blocks into the sockets on the device.

Removal

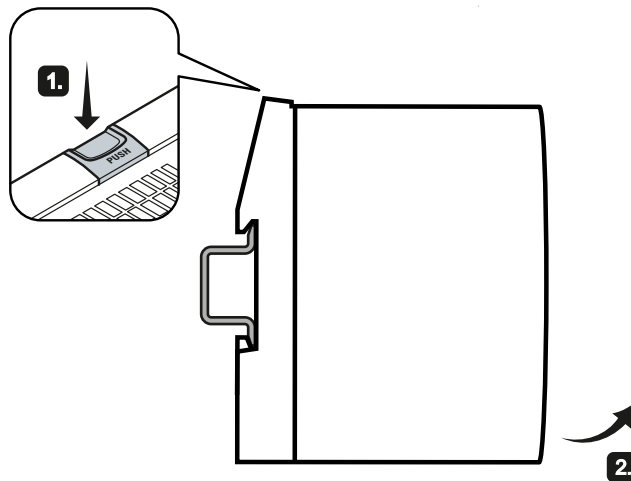

Figure 4-2 Removing from a DIN rail

To remove the device from a DIN rail, follow the steps below:

1. Disconnect all connected cables.
2. Release the DIN rail locking mechanism by pressing down on the release button ①.
3. Pull the lower part of the device away from the DIN rail ②.

Connecting up

5.1 Safety when connecting up

Safety notices

When connecting up the device, keep to the safety notices listed below.

 WARNING
The equipment is designed for operation with Safety Extra-Low Voltage (SELV) by a Limited Power Source (LPS).
This means that only SELV / LPS complying with IEC 60950-1 / EN 60950-1 / VDE 0805-1 must be connected to the power supply terminals, or the power supply unit for the equipment power supply must comply with NEC Class 2, as described by the National Electrical Code (r) (ANSI / NFPA 70).
If the equipment is connected to a redundant power supply (two separate power supplies), both must meet these requirements.

Safety notices on use in hazardous areas

General safety notices relating to protection against explosion

 WARNING
EXPLOSION HAZARD
Do not connect or disconnect cables to or from the device when a flammable or combustible atmosphere is present.

Safety notices when using the device according to Hazardous Locations (HazLoc)

If you use the device under HazLoc conditions you must also keep to the following safety notices in addition to the general safety notices for protection against explosion:

 WARNING
EXPLOSION HAZARD
You may only connect or disconnect cables carrying electricity when the power supply is switched off or when the device is in an area without inflammable gas concentrations.

Safety notices for use according to ATEX and IECEx

If you use the device under ATEX or IECEx conditions you must also keep to the following safety notices in addition to the general safety notices for protection against explosion:

 **WARNING**

Take measures to prevent transient voltage surges of more than 40% of the rated voltage. This is the case if you only operate devices with SELV (safety extra-low voltage).

 **WARNING**

Provisions shall be made to prevent the rated voltage from being exceeded by transient disturbances of more than 119 V.

 **WARNING**

Safety notice for connecting with a LAN ID (Local Area Network)

A LAN or LAN segment with all the interconnected devices should be contained completely in a single low voltage power distribution in a building. The LAN is designed either for "Environment A" according to IEEE802.3 or "Environment 0" according to IEC TR 62102.

Do not connect any electrical connectors directly to the telephone network (telephone network voltage) or a WAN (Wide Area Network).

Safety notices when using the device according to ATEX/IECEx and FM

If you use the device under ATEX/IECEx or FM conditions, you must also observe the following safety notices in addition to the general safety notices for protection against explosion:

 **WARNING**

Do not remove or replace while circuit is live when a flammable or combustible atmosphere is present.

5.2 Industrial Ethernet

5.2.1 Electrical

Note

Strain relief for the Ethernet cables

In order to avoid mechanical stress on the Ethernet cables and resulting interruption of the contact, fasten the cables at a short distance from the connector using a cable guide or busbar.

R-45 connector technology

The attachment to Industrial Ethernet uses RJ-45 connected technology with MDI-X assignment.

Pin assignment

The following table shows the pin assignment of the R-45 connectors.

Pin number	Assignment	R-45 connector
Pin 1	RD+	 12345678
Pin 2	RD-	
Pin 3	TD+	
Pin 4	n. c. (Not connected)	
Pin 5	n. c. (Not connected)	
Pin 6	TD-	
Pin 7	n. c. (Not connected)	
Pin 8	n. c. (Not connected)	

MDI / MDI-X autocrossover

With the MPI/MDI-X autocrossover function, the send and receive contacts of an Ethernet port are assigned automatically. The assignment depends on the cable with which the communications partner is connected. This means that it does not matter whether the port is connected using a patch cable or crossover cable. This prevents malfunctions resulting from mismatching send and receive wires. This makes installation much easier for the user.

Note

Formation of loops

Please note that the direct connection of two ports on the IE switch or accidental connection over several IE switches causes an illegal loop. Such a loop can lead to network overload and network failures.

Autonegotiation

Autonegotiation means the automatic detection/negotiation of the transmission rate and the operating mode of ports at the opposite end. This makes it possible to configure different devices automatically.

Two components connected to a link segment can exchange information about the transfer and can adapt their settings to each other. The mode with the highest possible speed is set.

Note

- If a port is set permanently to full duplex, the connected partner port must also be set to full duplex.
- If a port operating in the "Auto negotiation" mode is connected to a partner port that is not operating in the "Auto negotiation" mode, the partner port setting must be fixed at 100 Mbps or 10 Mbps half duplex mode.
- If you disable the "Auto negotiation" function, the "MDI/MDI-X autocrossover" function is also turned off. Then use a crossover cable.

5.2.2 Optical

<p>NOTICE</p> <p>Failure of the data traffic due to contamination of optical plug-in connections</p> <p>Optical sockets and plugs are sensitive to contamination of the end face. Contamination can lead to the failure of the optical transmission network. Take the following precautions to avoid functional impairments:</p> <ul style="list-style-type: none">• Clean the end face of field-assembled connectors carefully before connecting. No residues of processing may remain on the connector.• Only remove the dust caps of optical transceivers and pre-configured cables shortly before connecting the cables.• Close unused optical sockets and plugs as well as pluggable transceivers and slots with the supplied protective caps.

Note

No light power measurement (PROFINET diagnostics)

The devices do not support diagnostics with light power measurement.

SC connectors

The attachment to Industrial Ethernet uses SC connector technology (Subscriber Connector).

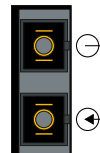

ST/BFOC connectors

The attachment to Industrial Ethernet uses ST/BFOC connector technology (Straight Tip/Bayonet Fiber Optic Connector).

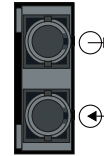

5.3 Wiring rules

When wiring use cables with the following AWG categories or cross sections.

Wiring rules for ...		Spring-loaded terminals
connectable cable cross sections for flexible cables ...	without wire end ferrule	0.2 - 1.5 mm ² AWG: 24 - 14
	with wire end ferrule with plastic ferrule**	0.25 - 0.75 mm ² AWG: 24 - 14
	with TWIN wire end ferrule without plastic ferrule**	0.25 - 1.5 mm ² AWG: 24 - 18
Stripped length of the cable		10 mm
Wire end ferrule according to DIN 46228 without plastic ferrule**		10 mm

* AWG: American Wire Gauge

** See note "Wire end ferrules"

Note

Wire end ferrules

Use crimp shapes with smooth surfaces, such as provided by square and trapeze shaped crimp cross sections.

Crimp shapes with wave-shaped profile are unsuitable.

5.4 Power supply

Notes on the power supply

 **WARNING**

Incorrect power supply

The power supply unit for supplying the devices must comply with NEC Class 2 or LPS:

- Voltage range 19.2 - 28.8 V for AC or DC
- Power consumption max. 450 mA for AC
- Power consumption max. 300 mA for DC

Do not operate the devices with AC voltages higher than 28.8 V AC.

Do not operate the devices with DC voltages higher than 28.8 V DC.

 **CAUTION**

Damage to the device due to overvoltage

The connector of the external power supply is not protected against strong electromagnetic pulses that can, for example, result from lightning strikes or switching large loads.

One of the tests used to attest the immunity of devices of the IE switches SCALANCE XB-100 to electromagnetic interference, among others, is the "surge immunity test" according to EN61000-4-5. This test requires overvoltage protection for the power supply lines. A suitable device is, for example, the Dehn Blitzductor BVT AVD 24, article number 918 422 or a comparable protective element. An example of a suitable device for AC operation is the Blitzductor BXT ML2 BD S 48, art. no. 920 245, in combination with the basic unit BXT BAS, art. no. 920 300, or a comparable protective element.

Manufacturer: DEHN+SOEHNE GmbH+Co.KG, Hans-Dehn-Str.1, Postfach 1640, D92306 Neumarkt, Germany

Operate the SCALANCE XB-100 with suitable overvoltage protection.

Information on the power supply

- The power supply is connected using a 3-pin plug-in terminal block (spring-loaded terminal). The terminal block ships with the device and can also be ordered as a spare part.
- The power supply can be connected redundantly. Both inputs are isolated. There is no distribution of load.
- The power supply is connected over a high resistance with the enclosure to allow an ungrounded set up. The two power inputs are non-floating.
- Note the wiring rules.

Position and assignment

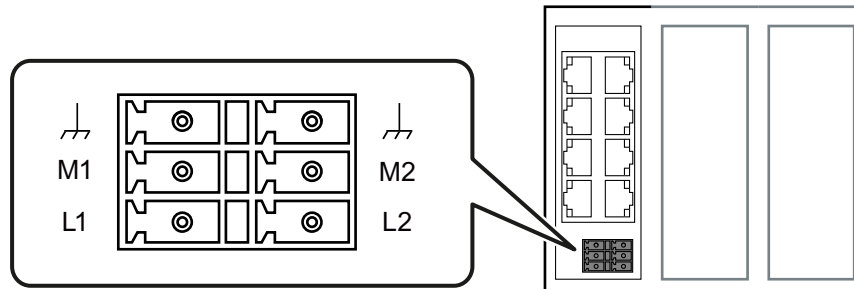



Figure 5-1 Position of the power supply using the SCALANCE XB124 as an example

Contact	Assignment	Assignment	Contact
	Functional ground	Functional ground	
M1	Ground	Ground	M2
L1	24 V AC/VDC	24 V AC/VDC	L2

5.5 Functional ground

EMC disturbances are diverted to ground via the functional ground. This ensures the immunity of the data transmission.

The functional ground must be implemented with low impedance. The connection of the functional ground must be established directly on the mounting plate or the DIN rail terminal.

The IE switch has a terminal for functional ground, refer to the section "Power supply (Page 28)". Keep to the specified cross-sectional area for the functional ground.

The terminal is identified by the following symbol for the functional ground .

Follow the steps below to connect the functional ground:

1. Connect the terminal of the IE switch with as short a cable as possible ≤ 150 mm and with the required cross-sectional area to a grounded part of the system (DIN rail).
2. Connect the DIN rail with the ground of the system.

Protective/functional ground

The connection of the reference potential surface with the protective ground system is normally in the cabinet close to the power feed-in. This ground conducts fault currents to ground safely and according DIN/VDE 0100 is a protective ground to protect people, animals and property from too high contact voltages.

Apart from the protective ground, there is functional grounding in the cabinet. According to EN60204-1 (DIN/VDE 0113 T1) electrical circuits must be grounded. The chassis (0 V) is grounded at one defined point. Here, once again the grounding is implemented with the lowest leakage resistance to ground in the vicinity of the power feed-in.

5.5 Functional ground

With automation components, functional ground also ensures interference-free operation of a controller. Via the functional ground, interference currents coupled in via the connecting cables are discharged to ground.

Upkeep and maintenance

LED display when voltage is too low

If the power supply is too low, then the internal power supply will switch off causing the Power LED and all port LEDs to go off. The functionality of the SCALANCE XB-100 is no longer available. A power supply of at least 19.2 V is necessary for correct operation.

Device defective

If a fault develops, please send the device to your SIEMENS service center for repair. Repairs on-site are not possible.

Technical specifications

7.1 Technical specifications of the SCALANCE XB108-2(SC)

The following technical specifications apply to the SCALANCE XB108-2(SC).

Technical specifications		
Electrical data		
Power supply	Rated voltage	24 V AC/VDC
	Voltage range	19.2 to 28.8 V AC/VDC Safety Extra Low Voltage (SELV)
	Design	Terminal block, 3 terminals
	Properties	Implemented redundantly
Current consumption	At 24 V AC	450 mA
	At 24 V DC	300 mA
Effective power loss	At 24 V AC	10.8 VA
	At 24 V DC	7.2 W
Fusing		F 2.5 A / 125 V
Permitted ambient conditions		
Ambient temperature	During operation up to 3000 m	0 °C to +60 °C
	During storage	-40 °C to +85 °C
	During transportation	-40 °C to +85 °C
Relative humidity	During operation at 25 °C	≤ 95 % no condensation
Housing, dimensions and weight		
Design	compact	
Housing material	Polycarbonate (PC-GF10)	
Degree of protection	IP20	
Dimensions (W x H x D)	80 x 117 x 109 mm	
Weight	340 g	
Installation options	Installation on a DIN rail	
Mean time between failure (MTBF)		
MTBF (EN/IEC 61709; 40 °C)	> 71 years	

Attachment to Industrial Ethernet

Electrical connectors

Properties	
Quantity	8
Connector	RJ45 jack

7.2 Technical specifications of the SCALANCE XB108-2(ST)

Properties	
Properties	Half/full duplex, MDI-X pinning
Transmission speed	10 / 100 Mbps

Optical connectors

Optical connectors	
Quantity	2



The attachment to Industrial Ethernet uses SC connector technology (Subscriber Connector).

Properties		
Transmission mode	100Base-FX complying with IEEE 802.3	
Transmission speed	100 Mbps (Fast Ethernet)	
Transmission medium	Multimode fiber-optic cable	
Light source	LED/Class1-LASER "Eye safe"	
Wavelength	1300 nm	
Cable length (max.) *)	At 50 µm fiber core diameter	3 km
	At 62.5 µm fiber core diameter	3 km
Transmitter output (optical)	Minimum	At 50 µm -23.5 dBm
		At 62.5 µm -20 dBm
	Maximum	-14 dBm
Receiver input	Sensitivity min.	-31 dBm
	Input power max.	-8 dBm

*) Depending on the cable used, you can find additional information in the "Industrial Ethernet / PROFINET Passive network components" System Manual, see also section "Introduction", paragraph "Additional documentation".

7.2 Technical specifications of the SCALANCE XB108-2(ST)

The following technical specifications apply to the SCALANCE XB108-2(ST).

Technical specifications		
Electrical data		
Power supply	Rated voltage	24 V AC/VDC
	Voltage range	19.2 to 28.8 V AC/VDC Safety Extra Low Voltage (SELV)
	Design	Terminal block, 3 terminals
	Properties	Implemented redundantly

7.2 Technical specifications of the SCALANCE XB108-2(ST)

Technical specifications		
Current consumption	At 24 V AC	450 mA
	At 24 V DC	300 mA
Effective power loss	At 24 V AC	10.8 VA
	At 24 V DC	7.2 W
Fusing		F 2.5 A / 125 V
Permitted ambient conditions		
Ambient temperature	During operation up to 3000 m	0 °C to +60 °C
	During storage	-40 °C to +85 °C
	During transportation	-40 °C to +85 °C
Relative humidity	During operation at 25 °C	≤ 95 % no condensation
Housing, dimensions and weight		
Design	compact	
Housing material	Polycarbonate (PC-GF10)	
Degree of protection	IP20	
Dimensions (W x H x D)	80 x 117 x 109 mm	
Weight	340 g	
Installation options	Installation on a DIN rail	
Mean time between failure (MTBF)		
MTBF (EN/IEC 61709; 40 °C)	> 71 years	

Attachment to Industrial Ethernet

Electrical connectors

Properties	
Quantity	8
Connector	RJ45 jack
Properties	Half/full duplex, MDI-X pinning
Transmission speed	10 / 100 Mbps

Optical connectors

Optical connectors	
Quantity	2
Connectors	

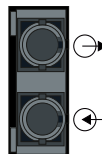

The attachment to Industrial Ethernet uses ST/BFOC connector technology (Straight Tip/Bayonet Fiber Optic Connector).

7.3 Technical specifications of the SCALANCE XB112

Properties			
Transmission mode	100Base-FX complying with IEEE 802.3		
Transmission speed	100 Mbps (Fast Ethernet)		
Transmission medium	Multimode fiber-optic cable		
Light source	LED/Class1-LASER "Eye safe"		
Wavelength	1300 nm		
Cable length (max.) *)	At 50 µm fiber core diameter	3 km	
	At 62.5 µm fiber core diameter	3 km	
Transmitter output (optical)	Minimum	At 50 µm	-23.5 dBm
		At 62.5 µm	-20 dBm
	Maximum	-14 dBm	
Receiver input	Sensitivity min.	-31 dBm	
	Input power max.	-8 dBm	

*) Depending on the cable used, you can find additional information in the "Industrial Ethernet / PROFINET Passive network components" System Manual, see also section "Introduction", paragraph "Additional documentation".

7.3 Technical specifications of the SCALANCE XB112

The following technical specifications apply to the SCALANCE XB112.

Technical specifications		
Electrical data		
Power supply	Rated voltage	24 V AC/VDC
	Voltage range	19.2 to 28.8 V AC/VDC Safety Extra Low Voltage (SELV)
	Design	Terminal block, 3 terminals
	Property	Implemented redundantly
Current consumption	At 24 V AC	350 mA
	At 24 V DC	200 mA
Effective power loss	At 24 V AC	8.4 VA
	At 24 V DC	4.8 W
Fusing	F 2.5 A / 125 V	
Permitted ambient conditions		
Ambient temperature	During operation up to 3000 m	0 °C to +60 °C
	During storage	-40 °C to +85 °C
	During transportation	-40 °C to +85 °C
Relative humidity	During operation at 25 °C	≤ 95 % no condensation
Housing, dimensions and weight		
Design	compact	
Housing material	Polycarbonate (PC-GF10)	

Technical specifications	
Degree of protection	IP20
Dimensions (W x H x D)	80 x 117 x 109 mm
Weight	345 g
Installation options	Installation on a DIN rail
Mean time between failure (MTBF)	
MTBF (EN/IEC 61709; 40 °C)	> 83 years

Attachment to Industrial Ethernet

Properties	
Quantity	12
Connector	RJ45 jack
Properties	Half/full duplex, MDI-X pinning
Transmission speed	10 / 100 Mbps

7.4 Technical specifications of the SCALANCE XB116

The following technical specifications apply to the SCALANCE XB116.

Technical specifications		
Electrical data		
Power supply	Rated voltage	24 V AC/VDC
	Voltage range	19.2 to 28.8 V AC/VDC Safety Extra Low Voltage (SELV)
	Design	Terminal block, 3 terminals
	Property	Implemented redundantly
Current consumption	At 24 V AC	350 mA
	At 24 V DC	200 mA
Effective power loss	At 24 V AC	8.4 VA
	At 24 V DC	4.8 W
Fusing		F 2.5 A / 125 V
Permitted ambient conditions		
Ambient temperature	During operation up to 3000 m	0 °C to +60 °C
	During storage	-40 °C to +85 °C
	During transportation	-40 °C to +85 °C
Relative humidity	During operation at 25 °C	≤ 95 % no condensation
Housing, dimensions and weight		
Design	compact	
Housing material	Polycarbonate (PC-GF10)	
Degree of protection	IP20	
Dimensions (W x H x D)	80 x 117 x 109 mm	

7.5 Technical specifications of the SCALANCE XB124

Technical specifications	
Weight	375 g
Installation options	Installation on a DIN rail
Mean time between failure (MTBF)	
MTBF (EN/IEC 61709; 40 °C)	> 80 years

Attachment to Industrial Ethernet

Properties	
Quantity	16
Connector	RJ45 jack
Properties	Half/full duplex, MDI-X pinning
Transmission speed	10 / 100 Mbps

7.5 Technical specifications of the SCALANCE XB124

The following technical specifications apply to the SCALANCE XB124.

Technical specifications		
Electrical data		
Power supply	Rated voltage	24 V AC/VDC
	Voltage range	19.2 to 28.8 V AC/VDC Safety Extra Low Voltage (SELV)
	Design	Terminal block, 3 terminals
	Property	Implemented redundantly
Current consumption	At 24 V AC	450 mA
	At 24 V DC	300 mA
Effective power loss	At 24 V AC	10.8 VA
	At 24 V DC	7.2 W
Fusing		F 2.5 A / 125 V
Permitted ambient conditions		
Ambient temperature	During operation up to 3000 m	0 °C to +60 °C
	During storage	-40 °C to +85 °C
	During transportation	-40 °C to +85 °C
Relative humidity	During operation at 25 °C	≤ 95 % no condensation
Housing, dimensions and weight		
Design	compact	
Housing material	Polycarbonate (PC-GF10)	
Degree of protection	IP20	
Dimensions (W x H x D)	120 x 117 x 109 mm	
Weight	535 g	
Installation options	Installation on a DIN rail	

Technical specifications

Mean time between failure (MTBF)

MTBF (EN/IEC 61709; 40 °C) > 57 years

Attachment to Industrial Ethernet

Properties	
Quantity	24
Connector	RJ45 jack
Properties	Half/full duplex, MDI-X pinning
Transmission speed	10 / 100 Mbps

7.6 Cable lengths

The cable lengths listed below apply to the SCALANCE XB-100.

Cable	Permitted cable length
IE TP torsion cable with IE FC Outlet RJ-45 + 10 m TP cord	0 to 45 m + 10 m TP cord
IE TP torsion cable with IE FC RJ-45 Plug 180	0 to 55 m
IE FC TP Marine / Trailing / Flexible cable with IE FC Outlet RJ-45 + 10 m TP cord	0 to 75 m + 10 m TP cord
IE FC TP Marine / Trailing / Flexible cable with IE FC RJ-45 Plug 180	0 to 85 m
IE FC TP standard cable with IE FC Outlet RJ-45 + 10 m TP cord	0 to 90 m + 10 m TP cord
IE FC TP standard cable with IE FC RJ-45 Plug 180	0 to 100 m

7.7 Switching properties

The switching properties listed below apply to the SCALANCE XB-100.

Switching properties	
Aging time	45 seconds
Max. number of learnable addresses	1024
Response to LLDP frames	Blocking
Response to spanning tree BPDU frames	Forwarding
CoS acc. to IEEE 802.1Q	Yes
QoS priority queues	4
Switching technique	Store and forward

7.7 Switching properties

Switching properties	
IEEE 802.1Q tags (VLAN ID, priority) transparent forwarding	Yes
Maximum frame size	1536 bytes
Forwarding of PRP frames (Parallel Redundancy Protocol)	Yes

Note

The number of SCALANCE XB-100 modules connected in a line influences the frame delay. When a frame passes through the IE switch, this is delayed by the store-and-forward function of the SCALANCE XB-100 by 10-130 microseconds (at 100 Mbps).

Mechanical stability (in operation)

Device	IEC 60068-2-27 shock	IEC 60068-2-6 vibration
	15 g, 11 ms duration 6 shocks per axis	10 - 58 Hz: 0.075 mm 85 - 150 Hz: 1 g 1 octave/min, 20 sweeps
SCALANCE XB108-2(SC)	•	•
SCALANCE XB108-2(ST)	•	•
SCALANCE XB112	•	•
SCALANCE XB116	•	•
SCALANCE XB124	•	•

Dimension drawings

Note

Dimensions are specified in mm.

Front view of the SCALANCE XB108-2, SCALANCE XB112 and SCALANCE XB116

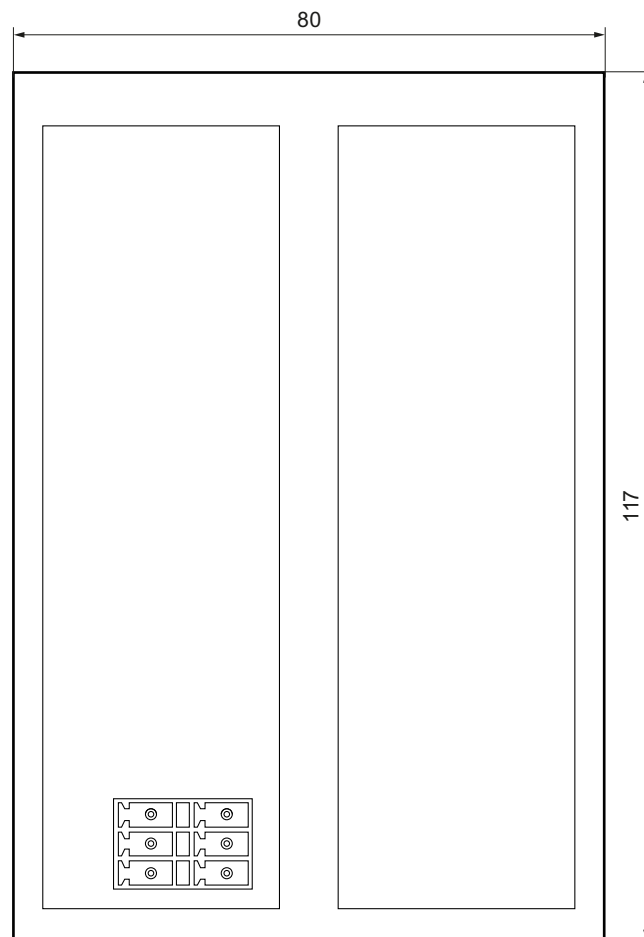

Figure 8-1 Width and height

Front view of the SCALANCE XB124

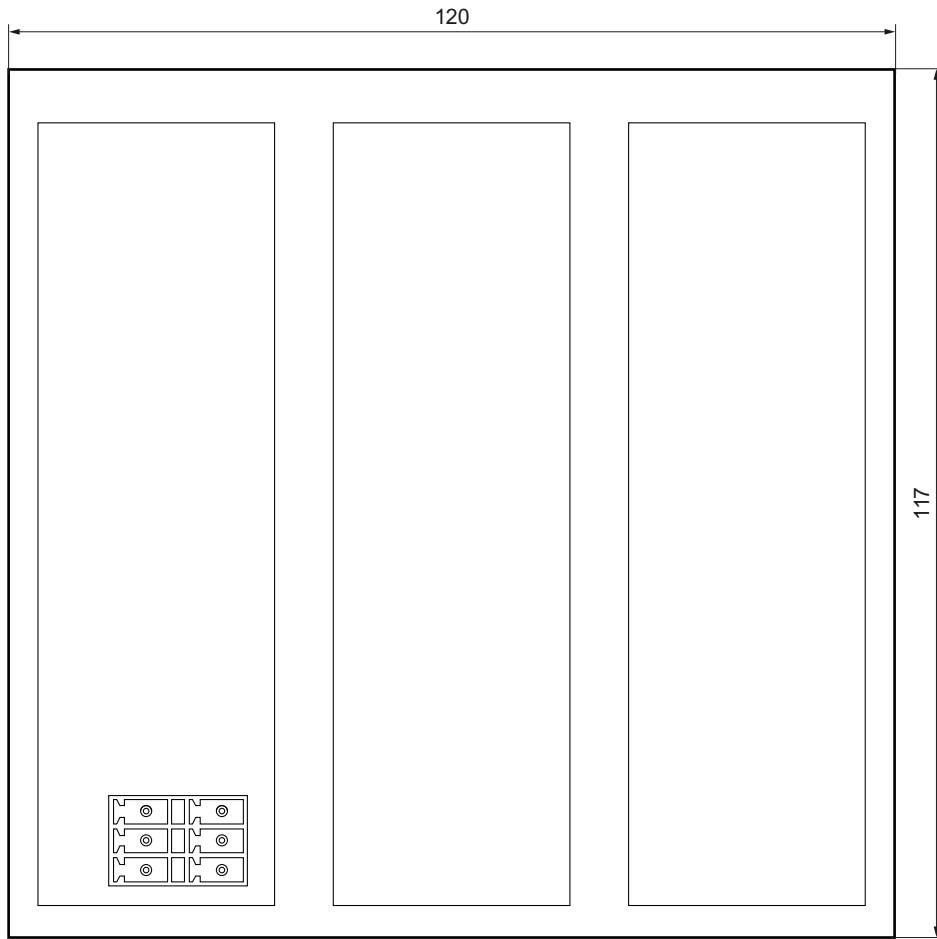

Figure 8-2 Width and height

Side view of the SCALANCE XB-100

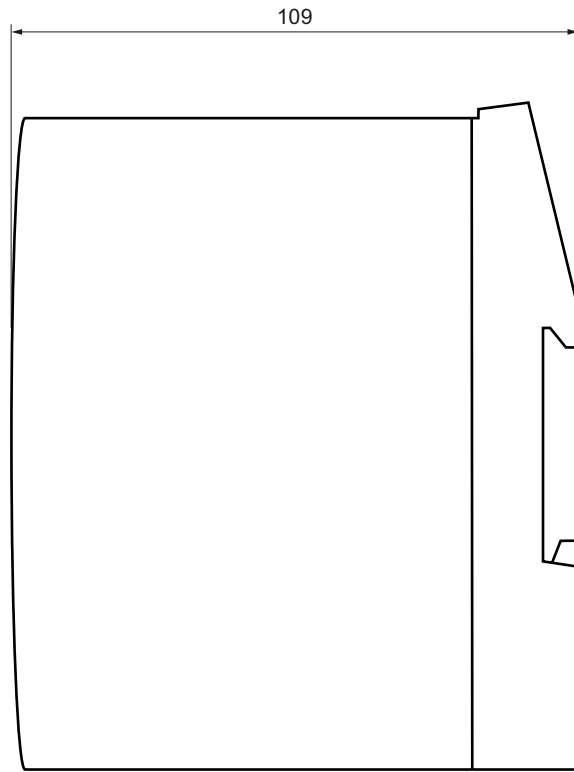

Figure 8-3 Depth

Approvals

The SIMATIC NET products described in these Operating Instructions have the approvals listed below.

Note**Issued approvals on the type plate of the device**

The specified approvals apply only when the corresponding mark is printed on the product. You can check which of the following approvals have been granted for your product by the markings on the type plate.

Current approvals on the Internet

You will find the current approvals for the product on the Internet pages of Siemens Industry Online Support (<http://support.automation.siemens.com/WW/view/en/33118389/134200>).

Notes for the manufacturers of machines

The devices are not machines in the sense of the EC Machinery Directive. There is therefore no declaration of conformity relating to the EC Machinery Directive 2006/42/EC for these devices.

If the devices are part of the equipment of a machine, they must be included into the EU declaration of conformity procedure by the manufacturer of the machine.

See also

SIMATIC NET Industrial Ethernet TP and Fiber Optic Networks (<http://support.automation.siemens.com/WW/view/en/8763736>)

EC declaration of conformity



The SIMATIC NET products described in these operating instructions meet the requirements and safety objectives of the following EC directives and comply with the harmonized European

standards (EN) which are published in the official documentation of the European Union and here.

- **2014/34/EU (ATEX explosion protection directive)**
Directive of the European Parliament and the Council of 26 February 2014 on the approximation of the laws of the member states concerning equipment and protective systems intended for use in potentially explosive atmospheres, official journal of the EU L96, 29/03/2014, pages. 309-356
- **2014/30/EU (EMC)**
EMC directive of the European Parliament and of the Council of February 26, 2014 on the approximation of the laws of the member states relating to electromagnetic compatibility; official journal of the EU L96, 29/03/2014, pages. 79-106
- **2011/65/EU (RoHS)**
Directive of the European Parliament and of the Council of 8 June 2011 on the restriction of the use of certain hazardous substances in electrical and electronic equipment, official journal of the EC L174, 01/07/2011, pages 88-110

You will find the EC declaration of conformity for these products on the Internet pages of Siemens Industry Online Support (<https://support.industry.siemens.com/cs/ww/en/ps/15273/cert>).

The EC Declaration of Conformity is available for all responsible authorities at:

Siemens Aktiengesellschaft
Division Process Industries and Drives
Process Automation
DE-76181 Karlsruhe
Germany

ATEX (explosion protection directive)

 WARNING
Risk of explosion in hazardous areas When using SIMATIC NET products in hazardous area zone 2, make absolutely sure that the associated conditions in the following document are adhered to: "SIMATIC NET Product Information Use of subassemblies/modules in a Zone 2 Hazardous Area". You will find this document here: <ul style="list-style-type: none">• On the data medium that ships with some products:<ul style="list-style-type: none">– Product CD / product DVD– SIMATIC NET Manual Collection• On the Internet pages of Siemens Industry Online Support (https://support.industry.siemens.com/cs/ww/en/view/78381013)

The SIMATIC NET products described in these operating instructions meet the requirements of the EU directive 2014/34/EU "Equipment and Protective Devices for Use in Potentially Explosive Atmospheres".

Note**Type of protection of the device**

The devices are approved for various types of protection. You can find the type of protection of your device and the ATEX certificate number on the nameplate.

Permitted types of protection

The following types of protection are possible:

- nA
ATEX classification: II 3G Ex nA IIC T4 Gc
Certificate no.: KEMA 07ATEX0145 X
The products meet the requirements of the following standards:
 - EN 60079-15 (Explosive atmospheres - Part 15: Equipment protection by type of protection "n")
 - EN 60079-0 (Explosive atmospheres - Part 0: Equipment - General requirements)
- nA [op is]
ATEX classification: II 3 (2) G Ex nA [op is Gb] IIC T4 Gc
Certificate no.: DEKRA 11ATEX0060 X
The products meet the requirements of the following standards:
 - EN 60079-28 (Explosive atmospheres - Part 28: Protection of equipment and transmission systems using with optical radiation)
 - EN 60079-15 (Explosive atmospheres - Part 15: Equipment protection by type of protection "n")
 - EN 60079-0 (Explosive atmospheres - Part 0: Equipment - General requirements)
- ec
ATEX classification: II 3 G Ex ec IIC T4 Gc
Certificate no.: DEKRA 18ATEX0025 X
The products meet the requirements of the following standards:
 - EN 60079-7 (Explosive atmospheres - Part 7: Equipment protection through increased safety "e")
 - EN 60079-0 (Explosive atmospheres - Part 0: Equipment - General requirements)

You will find the current versions of the standards in the currently valid ATEX certificates.

IECEX

The SIMATIC NET products described in these operating instructions meet the requirements of explosion protection according to IECEx.

Note

Type of protection of the device

The devices are approved for various types of protection. You can find the type of protection of your device and the IECEx certificate number on the nameplate.

Permitted types of protection

The following types of protection are possible:

- nA
IECEX classification: Ex nA IIC T4 Gc
Certificate no.: DEK 14.0025X
The products meet the requirements of the following standards:
 - IEC 60079-15 (Explosive atmospheres - Part 15: Equipment protection by type of protection "n")
 - IEC 60079-0 (Explosive atmospheres - Part 0: Equipment - General requirements)
- nA [op is]
IECEX classification: Ex nA [op is Gb] IIC T4 Gc
Certificate no.: DEK 14.0026X
The products meet the requirements of the following standards:
 - IEC 60079-28 (Explosive atmospheres - Part 28: Protection of equipment and transmission systems using with optical radiation)
 - IEC 60079-15 (Explosive atmospheres - Part 15: Equipment protection by type of protection "n")
 - IEC 60079-0 (Explosive atmospheres - Part 0: Equipment - General requirements)
- ec
IECEX classification: Ex ec IIC T4 Gc
Certificate no.: DEK 18.0017X
The products meet the requirements of the following standards:
 - IEC 60079-7 (Explosive atmospheres - Part 7: Equipment protection through increased safety "e")
 - IEC 60079-0 (Explosive atmospheres - Part 0: Equipment - General requirements)

You will find the current versions of the standards in the currently valid IECEx certificates.

Note for devices with CLASS 1 LASER

Important note on products certified according to Type Examination Certificate KEMA 07ATEX0145 X as of Issue 95 / DEKRA 18ATEX0025X and IECEx Certificate of Conformity DEK 14.0025X as of Issue 43 / DEK 18.0017X and containing Class 1 optical radiation sources.

Note

CLASS 1 LASER

The device contains optical radiation sources which comply with the limits of Class 1 according to IEC 60825-1. Fiber-optic cables connected to these optical radiation sources may therefore be routed either to or through hazardous areas requiring Category 2G, 3G, 2D or 3D equipment.

EMC directive (electromagnetic compatibility)

The SIMATIC NET products described in these operating instructions meet the requirements of EU directive 2014/30/EU "Electromagnetic Compatibility" (EMC Directive).

Applied standards:

- EN 61000-6-2 Electromagnetic compatibility (EMC) - Part 6-2: Generic standards - Immunity for industrial environments
- EN 61000-6-4 Electromagnetic compatibility (EMC) - Part 6-4: Generic standards - Emission standard for industrial environments

You will find the current versions of the standards in the currently valid EC declaration of conformity.

RoHS

The SIMATIC NET products described in these operating instructions meet the requirements of the EC directive 2011/65/EC for the restriction of the use of certain hazardous substances in electrical and electronic equipment:

Applied standard:

- EN 50581

FM

The product meets the requirements of the standards:

- Factory Mutual Approval Standard Class Number 3611
- FM Hazardous (Classified) Location Electrical Equipment:
Non Incendive / Class I / Division 2 / Groups A,B,C,D / T4 and
Non Incendive / Class I / Zone 2 / Group IIC / T4

cULus Approval for Information Technology Equipment

cULus Listed I. T. E.

Underwriters Laboratories Inc. complying with

- UL 60950-1 (Information Technology Equipment)
- CSA C22.2 No. 60950-1-03

Report no. E115352

cULus approval for industrial control equipment

cULus Listed IND. CONT. EQ.

Underwriters Laboratories Inc. complying with

- UL 61010-2-201
- CAN/CSA-IEC 61010-2-201

Report no. E85972

cULus Approval Hazardous Location

cULus Listed I. T. E. FOR HAZ. LOC.

Underwriters Laboratories Inc. complying with

- UL 60950-1 (Information Technology Equipment)
- ANSI/ISA 12.12.01-2007
- CSA C22.2 No. 213-M1987

Approved for use in

Cl. 1, Div. 2, GP A, B, C, D T4

Cl. 1, Zone 2, GP IIC T4

Report no. E240480

Note for Australia - RCM

The product meets the requirements of the RCM standard.

Applied standards:

- AS/NZS CISPR11 (Industrial, scientific and medical equipment - Radio-frequency disturbance characteristics - Limits and methods of measurement).
- EN 61000-6-4 Electromagnetic compatibility (EMC) - Part 6-4: Generic standards - Emission standard for industrial environments

You will find the current versions of the standards in the currently valid RCM SDoCs (Self-Declaration of Conformity).

MSIP 요구사항 - For Korea only

A급 기기(업무용 방송통신기자재)

이 기기는 업무용(A급) 전자파 적합기기로서 판매자 또는 사용자는 이 점을 주의하시기 바라며, 가정 외의 지역에서 사용하는 것을 목적으로 합니다.

Marking for the customs union



EAC (Eurasian Conformity)

Eurasian Economic Union of Russia, Belarus, Armenia, Kazakhstan and Kyrgyzstan

Declaration of conformity according to the technical regulations of the customs union (TR ZU)

FDA and IEC marking

The following devices meet the FDA and IEC requirements listed below:

Device	CLASS 1 LASER Product
SCALANCE XB108-2(SC)	•
SCALANCE XB108-2(ST)	•
SCALANCE XB112	-
SCALANCE XB116	-
SCALANCE XB124	-



Figure A-1 FDA and IEC approvals

<p>⚠ CAUTION</p> <p>Use of controls or adjustments or performance of procedures other than those specified herein may result in hazardous radiation exposure.</p>
--

Installation guidelines

The devices meet the requirements if you adhere to the installation and safety instructions contained in this documentation and in the following documentation when installing and operating the devices.

- "Industrial Ethernet / PROFINET Industrial Ethernet" System Manual (<https://support.industry.siemens.com/cs/ww/en/view/27069465>)
- "Industrial Ethernet / PROFINET - Passive Network Components" System Manual (<https://support.industry.siemens.com/cs/ww/en/view/84922825>)
- "EMC Installation Guidelines" configuration manual (<https://support.industry.siemens.com/cs/ww/en/view/60612658>)

 **WARNING**

Personal injury and property damage can occur

The installation of expansions that are not approved for SIMATIC NET products or their target systems may violate the requirements and regulations for safety and electromagnetic compatibility.

Only use expansions that are approved for the system.

Note

The test was performed with a device and a connected communications partner that also meets the requirements of the standards listed above.

When operating the device with a communications partner that does not comply with these standards, adherence to the corresponding values cannot be guaranteed.

Index

A

Accessories, 12
Ambient temperature, 33, 35, 36, 37, 38
Approvals, 45
Article numbers, 11
Autonegotiation, 25
AWG, 27

C

Cable cross section, 27
CE mark, 45
Components of the product, 12
Connecting up
 Grounding, 29
Cross section, 27

D

defective, 31
Dimensions, 33, 35, 36, 37, 38

E

Electrical data, 33, 34, 36, 37, 38
Environmental conditions, 33, 35, 36, 37, 38
Error
 LED display when voltage is too low, 31

G

Glossary, 6
Grounding, 13, 14, 15, 29

H

Housing, 33, 35, 36, 37, 38

I

Installation, 33, 35, 36, 37, 38
 Installation on a DIN rail, 21
Installation on a DIN rail, 21

L

LED display, 31
 Power LED, 16
LED displays, 15
 Port LEDs, 15

M

MDI / MDI-X autocrossover, 25
MTBF, 33, 35, 37, 38, 39

P

Permitted ambient conditions, 33, 35, 36, 37, 38
Pin assignment, 25
Power supply, 13, 14, 15, 28

R

Reduced voltage, 31

S

Safety notices
 for installation, 17
 general, 9
 Use in hazardous areas, 9, 17, 23
 when connecting up, 23
SIMATIC NET glossary, 6
SIMATIC NET manual, 6
Spare parts, 13
Spring-loaded terminal, 28
System manual, 6, 20, 51

W

Weight, 33, 35, 36, 37, 38
Wiring, 27

