

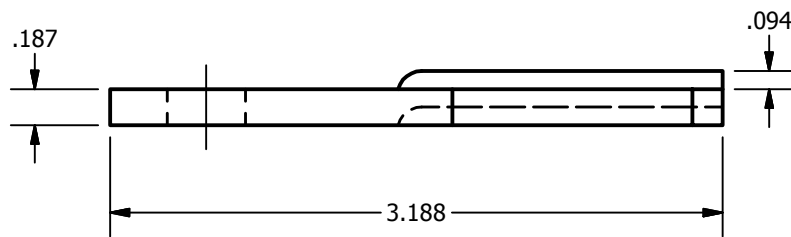

SCREW: NONE	MATERIAL: COPPER	REV: P	 800-776-9775 www.ilSCO.com
CAT. NO.: SLS-300	PLATING: SEE CHART	DRAWN BY: JG SCALE: 1=1	
INFORMATION SHEET: FORM 1	MARKING: SEE CHART	DATE: 6/18/2007 SIZE: A	
		DWG. NO.	<b>F0213</b>
		SHEET: 1 OF 1	

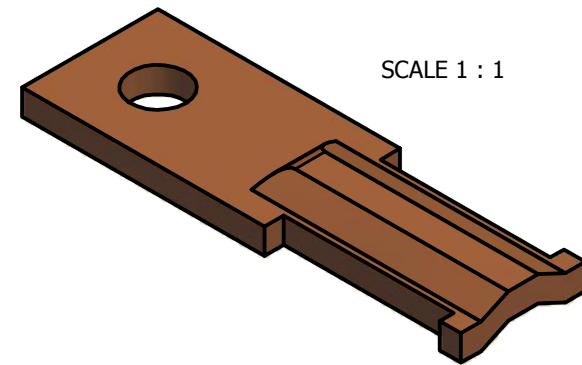
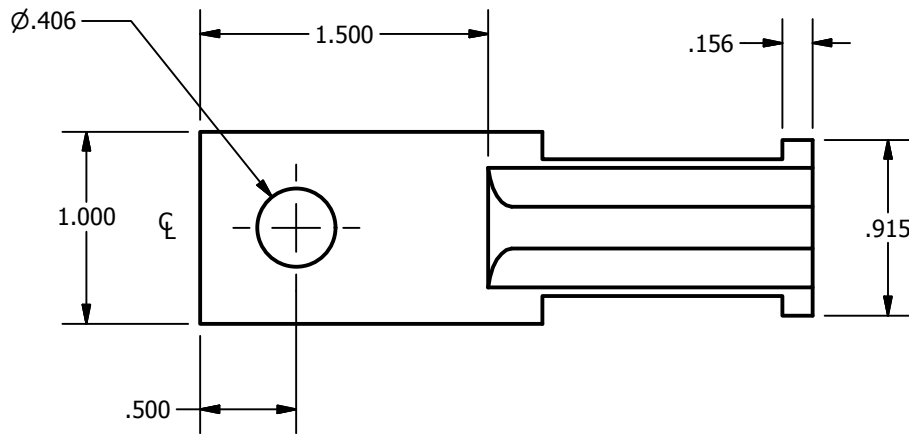

DEV	PLATING	MARKING
C00B	BRIGHT DIP	SLS300 
C00T	EL-TIN	SLS300 
C10B	BRIGHT DIP	