

## 2500 SERIES ELECTRIC BASEBOARD HEATERS

- MOUNTS FLUSH ON ANY FLOOR SURFACE
- SIXTEEN MODELS - 40 VARIATIONS
- AUTOMATIC SAFETY CUTOUT
- CONVENIENT WIRING COMPARTMENTS
- MOUNTING GUIDES FOR EASY INSTALLATION
- MAXIMUM CONVECTION DESIGN

For use in residential construction such as single family homes, apartments, modular or mobile homes as well as commercial, industrial and institutional construction as primary, secondary or supplemental heat for new construction or remodel applications.

- Easily installed without disassembly.
- Dual and triple ratings allow 16 models to cover 40 variations of wattage and voltage.
- Designed for quiet operation . . . no popping and pinging normally associated with baseboard heaters.
- Lead wires allow quick field connection to either end of heater.
- Continuous capillary tube safety thermal cutout protection in case of airflow blockage.
- Easy out knockouts at each end for convenient wiring. Knockouts inside wiring compartment allow field installation of optical raceway kit from end to end, forming UL listed wireway.
- 29 different accessories available.
- Chimney fin element design for maximum air circulation. Airflow is directed away from walls to help prevent wall soiling.
- UL listed for installation on wall at floor level with wall-to-wall carpeting. Heater stands unsupported during installation.
- Navajo White enamel finish retains attractive appearance and is compatible with all interior decors.
- Exclusive heating element design combines the durability of a steel tubular heater with the excellent heat transfer characteristics of aluminum fins.

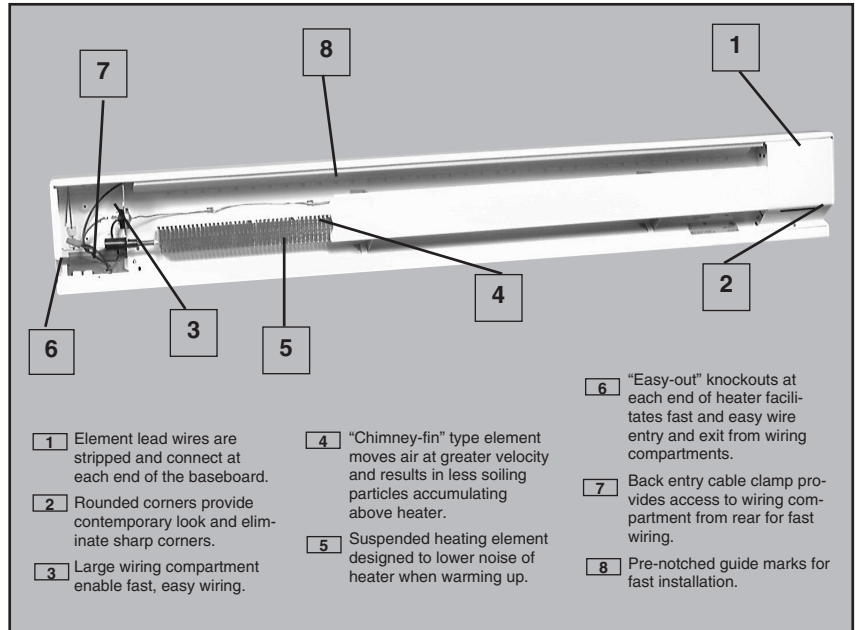
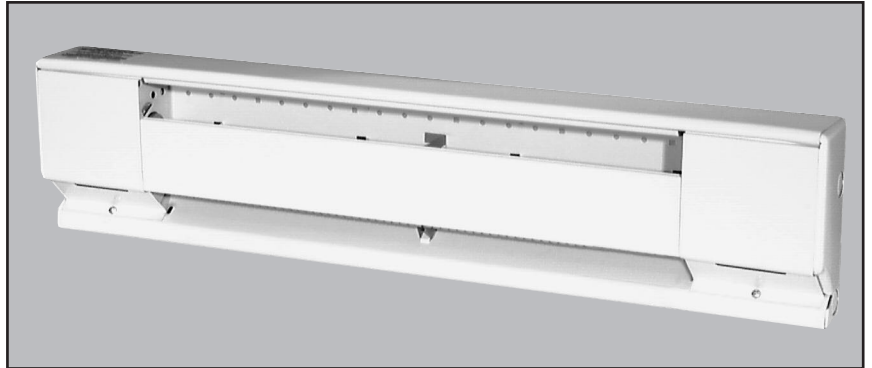

### ADDITIONAL FEATURES

- Mounting hole in rear of cabinet for fast, easy installation.
- Built-in cable clamp enables fast, easy wiring.
- Grounding wire pigtail in both junction boxes.
- 8', 2500 watt models.
- Rounded corners.

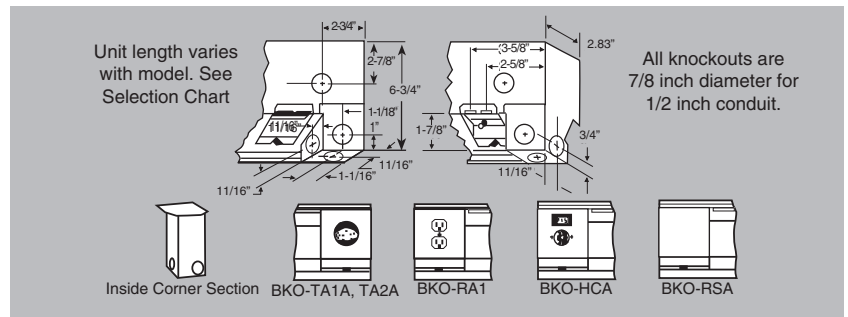

## SUGGESTED SPECIFICATIONS

Baseboard heaters shall be in full compliance with Underwriters Laboratories Label Service Standards without restriction.

Heaters shall have a totally enclosed nickel chromium resistance element with steel sheathing and shall have tempered aluminum alloy fins pressure bonded to the

sheathed element to provide conduction and resistance to accidental deflection.

Heaters shall have field wiring compartments at either end with provisions for a wireway. End caps shall be 20 gauge steel. Face plates shall not require removal to mount and wire the heater. Finish shall be enamel finish.

## SELECTION CHART

CATALOG NO.				WATTS	BTU/HR OUTPUT	LENGTH	WEIGHT (LBS.)
240 VOLT	120 VOLT	208 VOLT	277 VOLT				
<b>STANDARD DENSITY - 250 WATTS PER FOOT</b>							
2542W	2512W	2502W	2572W	400	1365	2'	5.2
2542-6W	2512-6W	2502-6W	2572-6W	500	1706	2'6"	6.3
2543W	2513W	2503W	2573W	750	2559	3'	7.5
2544W	2514W	2504W	2574W	1000	3412	4'	10.0
2545W	2515W	2505W	2575W	1250	4265	5'	11.5
2546W	2516W	2506W	2576W	1500	5118	6'	14.0
2548W	-	2508W	2578W	2000	6824	8'	18.5
25408W	-	25008W	25708W	2500	8530	8'	24.0
<b>DRAFT BARRIER DENSITY - 145 WATTS PER FOOT</b>							
-	-	2572W	-	225	768	2'	5.2
-	-	2572-6W	-	275	938	2'6"	6.3
-	-	2573W	-	425	1449	3'	7.5
-	-	2574W	-	565	1961	4'	10.0
-	-	2575W	-	725	2472	5'	11.5
-	-	2576W	-	875	2984	6'	14.0
-	-	2578W	-	1150	3921	8'	18.5
-	-	25708W	-	1450	4944	8'	24.0

**Color Option:** For Northern White colored baseboard, delete the "W" suffix from catalog number and add NW to suffix.

**High Altitude** Baseboard Heater (mounted above 7500 ft.), add suffix "H" to catalog number.

**NOTE:** Eight feet length baseboards, must be ordered in multiples of two pieces for shipment.

**NOTE:** Low watt density models and draft barrier models, do not require the "H" suffix for high altitude applications.

## ACCESSORIES

CATALOG NO.	DESCRIPTION	CASE QTY.	CASE WEIGHT (lbs.)
TA-1AW	Baseboard Thermostat, SP 22 Ampere, 40° to 100°F.	36	16
TA-2AW	Baseboard Thermostat, DP 22 Ampere, 40° to 100°F.	36	20
TA-1TPAW	Baseboard Thermostat, SP 22 Ampere, Tamperproof, 40° to 100°F	36	16
TA-2TPAW	Baseboard Thermostat, DP 22 Ampere, Tamperproof, 40° to 100°F	36	20
	Thermostats Rated 2500W @ 208V, 5000W @ 240/277V		
HCA12-15/20W	Heat-Cool Control, 125V. 15 and 20 AMP Receptacle.	40	57
HCA24-15/20W	Heat-Cool Control, 250V. connected to 20 AMP Max. Circuit	40	57
RA1COMPW	Duplex Receptacle Cover Only (Carton of 10)	1	1
RA-1W	Duplex Receptacle	36	10
1CAW	Inside Corner Allow 2-1/2" for installation	20	11
DSW2W	Double Pole Disconnect Switch Rated 20A @ 120-277V.	1	1
PR24	24 Volt AC, Class 2 Power Relay SPST 30A @ 120-240 VAC, 23A @ 277 VA	1	1
PR120	120 Volt AC, Class 2 Power Relay SPST 30A @ 120-240 VAC, 23A @ 277 VAC	1	1
RSA 12/24	Low Voltage Relay w/Transformer 120V/24V. -25A.	1	2
RSA 20/24	Low Voltage Relay w/Transformer 208V/24V. -25A.	1	2
RSA 24/24	Low Voltage Relay w/Transformer 240V/24V. -25A.	1	2
RSA 27/24	Low Voltage Relay w/Transformer 277V/24V. -25A.	1	2
<b>Filler Sections</b>			
CATALOG NO.	DESCRIPTION	SHIP WEIGHT (lbs.)	
FS12	1 Foot Filler Section	2	
FS24	2 Foot Filler Section	4	
FS36	3 Foot Filler Section	6	
FS48	4 Foot Filler Section	8	
FSJ2	2 Inch Joiner Strip	1/2	

**High Altitude** Baseboard Heater (mounted above 7500 ft.), add suffix "H" to catalog number.

**NOTE:** Eight feet length baseboards, must be ordered in multiples of two pieces for shipment.

**NOTE:** Low watt density models and draft barrier models, do not require the "H" suffix for high altitude applications.