



F-can (72C)

F-CAN HID 72C5782NP001

The Philips Advance line of F-can HID ballasts comes in two dual-voltage configurations for the US and Canadian market. Ballasts for these luminaires are most often encased and potted in fluorescent ballast type cans.

Product data

General Information		Open Circuit Voltage	
ANSI Code	M58	Open Circuit Voltage	300 V
Lamp Type	250W MH	Input Current (Nom)	2.6/1.12 A A
Number Of Lamps	1 piece/unit	Input Power (Nom)	290 W
Circuit Type	CWA	Rated Lamp Power	250W W
Ballast Type	Magnetic HID	Wiring	
Base Model	72C5782	Wire Striplength	0.5 mm
Suitable For Outdoor Use	Yes	Wire Length By Color	12"
Ignitor Catalog Number	NA	Wire Type	Stranded
Capacitor Catalog Number	Inside Can	Remote Wiring Configuration Allowed	Yes
Automatic Restart	No	Max Ballast-Lamp Distance Remote Wiring	Determined by AWG used
Operating and Electrical		Recommended Fuse Value	8/4 A
Input Voltage	120/277 V	Mechanical and Housing	
Input Frequency	60 Hz	Housing Material	Metal
Power (Rated) (Nom)	250 W	Housing	F-Can
Input Current (Open Circuit)	2.1/0.9 A	Housing Dimensions	16.7 x 2.63 x 3.19
Input Current (Starting)	2.1/0.9 A	Approval and Application	
Input Current (Short Circuit)	1.7-2.55/0.75-1.1 A	Open Circuit Voltage Test (Volts)	270-330 V
Secondary Short Circuit Current	2.15-2.65 A	Temperature Marking	90°C max. case
Constant Wattage Deviation	10%	UL Recognized	No
Ballast Factor (Nom)	1	Hipot Test (1 Minute)	1600 V
Power Factor (Nom)	0.90		

F-can (72C)

Hipot Test (2 Seconds)	2000 V
UL Insulation Class	A(105°C)
UL Temperature Code	NA

Product Data

Order product name	F-CAN HID 72C5782NP001
EAN/UPC - Product	781087025314

Order code	913710408901
Numerator - Quantity Per Pack	1
Numerator - Packs per outer box	1
Material Nr. (12NC)	913710408901
Net Weight (Piece)	7.036 kg

Dimensional drawing

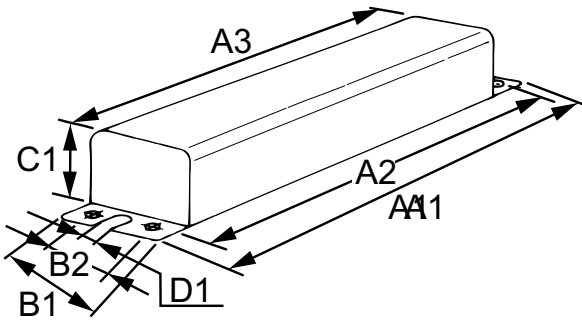

MH BAL 250W M58 120/277V FCAN

Product	A1	A2	A3	B1	B2	C1	D1
---------	----	----	----	----	----	----	----

