



► Model TELH

TelCom® Telephone Extension Ringer Device

Federal Signal's TELH Extension Ringer Device is a vibrating horn which is activated by the ringing signal of a telephone system. This device is specifically designed for use with an analog telephone. The ringing signal of 40-150VAC, 16-60Hz and local 120VAC power is all that is required to activate a TelCom® signal.

This TelCom device is intended to be mounted on a vertical surface such as a rigid wall or post. The TELH ringer has a three-conductor six-foot, 120VAC power cord extending from the unit. Connecting the TelCom device to the telephone network is accomplished by running a modular telephone line cord (RJ11) to an existing jack or a duplex jack (customer supplied) into an existing modular jack. The TELH is designed with a durable zinc die-cast housing painted with gray powder coat enamel, and features an internal solid-state relay.

Telcom devices are designed for high ambient noise areas such as manufacturing facilities, machine and sheet metal shops. They are also useful in large open areas such as a warehouse, loading dock or a large office.

FEATURES

- Available in 120VAC
- Horn signals incoming calls
- Activated by ringing voltage (analog telephone only)
- Type 1 enclosure
- 100 dBa @ 10' (110 dBa @ 1m)
- CSA Certified
- FCC Approved
- UL Listed for indoor use

MODEL	VOLTAGE	OPERATING CURRENT	DECIBELS	
			10'	1M
TELH	120VAC	0.222 amps	100	110

Telephone Extension Ringer Device (TELH)

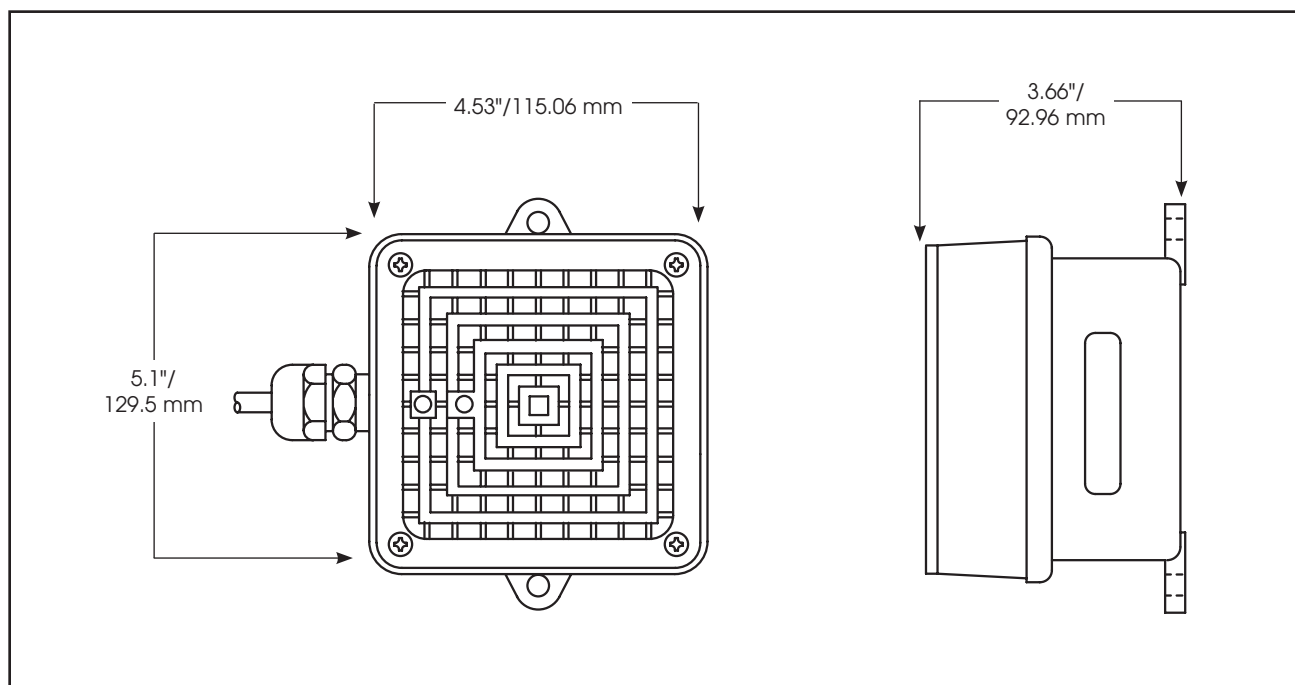

SPECIFICATIONS

Operating Temperature:	32°F to 112°F	0°C to 44°C
Ringing Signal:	90VAC, 20Hz	90VAC, 20Hz
Ring Detection:	15.8-60Hz, 40-150VAC	
Humidity Range (Storage and Operating):	0 to 85% R.H, noncondensing	
FCC Ringer Equivalence Number (REN):	1.0B	
Net Weight:	2.8 lbs	1.27 kg
Shipping Weight:	3.3 lbs	1.5 kg
Height:	5.1"	129.5 mm
Width:	4.53"	115.06 mm
Depth:	3.66"	92.96 mm

HOW TO ORDER

Specify Model:

TELH – TelCom® horn, 120VAC