

Technical Data

Technical Terms

Adjustable operating range — Total span within which the contacts can be adjusted to trip and reset.

Trip setting — Higher pressure setting at which value the contacts transfer from their normal state to a changed state.

Reset setting — Lower pressure setting at which value the contacts return to their normal state.

Adjustable differential — Difference between the trip and reset values.

Minimum differential — When the differential is set to the lowest pressure difference between trip and reset.

Maximum differential — When the differential is set to the widest pressure difference between trip and reset.

Maximum occasional surge pressure — Maximum surge pressure that can be applied to the actuator. Surges or transients can occur during startup and shutdown of a machine or system. Expressed in milliseconds, complex electronic instrumentation is required to measure the varying amplitude, frequency, and duration of this wave form. Extreme surges that occur approximately eight times in a 24-hour period are negligible.

Maximum line pressure — Maximum sustained pressure that can be applied to the bellows without permanent damage. The control should not be cycled at this pressure.

Positive pressure — Any pressure more than 0 psi. See Figure 2.

- **Trip setting** — Increasing pressure setting when contacts change state.
- **Reset setting** — Decreasing pressure setting when contacts return to their normal state.

Vacuum (negative pressure) — Any pressure less than 0 psi, inches of Hg vacuum. See Figure 2.

- **Trip setting** — Decreasing vacuum setting when contacts change state.
- **Reset setting** — Increasing vacuum setting when contacts return to their normal state.

psi — Pounds per square inch. Devices listed are in gauge pressure units which use atmospheric pressure as a reference. Atmospheric pressure at sea level is approximately 14.7 psi or 30 in. Hg.

Operating range adjustment screw — This screw is used to adjust the trip setting by varying the force of the main spring.

Differential adjustment screw — This screw is used to adjust reset setting by varying the force of the differential blade spring.

Pressure media — There are many types of pressure media that are controlled. Examples include air, water, hydraulic fluids and other types of gases and liquids. The type of media and maximum system pressure will determine the type of actuator used for the pressure control application. See page 13-9.

Pressure connection — Common types of pressure connections used in control systems are 1/4 in. and 3/8 in. female pipe threads, and 7/16 in. — 20 SAE copper tubing.

Contact configuration — There are many types of contact configurations available. Bulletin 836 Style A and C pressure controls offer a wide variety of contact configurations for both automatic operation and manual reset. See page 13-14.

Figure 1
Graphics to illustrate technical terms

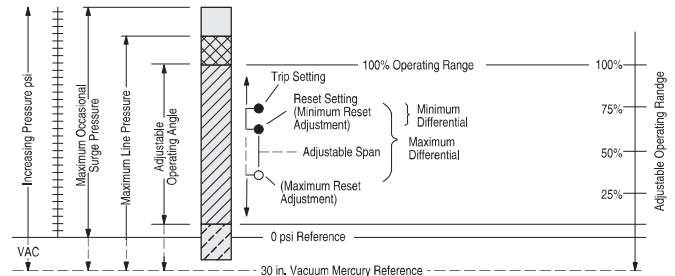
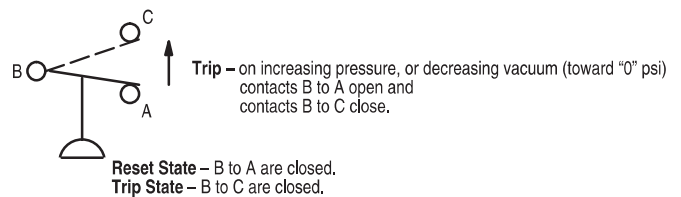

Figure 2
Positive pressure or vacuum



Theory of Operation

Bulletin 836 Pressure Controls are designed to open or close electrical circuits in response to changes in pneumatic (air or gas) or hydraulic (water or oil) pressure. Figure 3 is a simplified drawing of a pressure control.

The system pressure is connected to the control at the pressure connection. The system pressure is applied directly to the bellows. As pressure rises, the bellows exerts force on the main spring. When the threshold force of the main spring is overcome, it transfers the motion to the contact block, causing the contacts to actuate — this is referred to as the trip setting. As pressure decreases, the main spring will retract, causing the secondary differential blade spring to activate and return the contacts to their normal state — this is referred to as the reset setting.

Varying the force of the main spring (by turning the operating range adjustment screw) determines where the contacts will trip. Varying the force of the secondary differential blade spring (by turning the differential adjustment screw) determines where the contacts will reset.

Figure 3
Basic mechanical structure

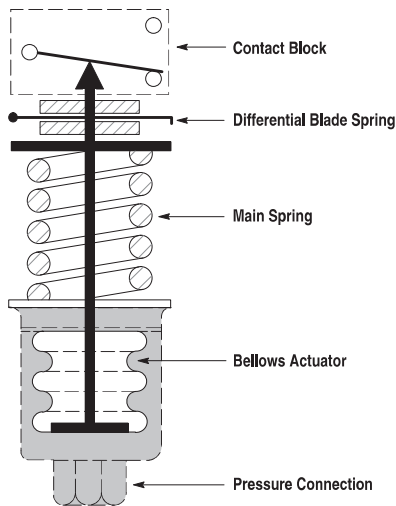

Applications for Control

Pressure controls can be used to either control or monitor a machine or process. Figure 4 shows a typical control application. Here, pressure is controlled within predetermined high and low values. Figure 5 shows a typical monitoring application. Here, pressure is monitored between a high and low value, signaling when a preset limit has been exceeded.

Figure 4
Typical control application

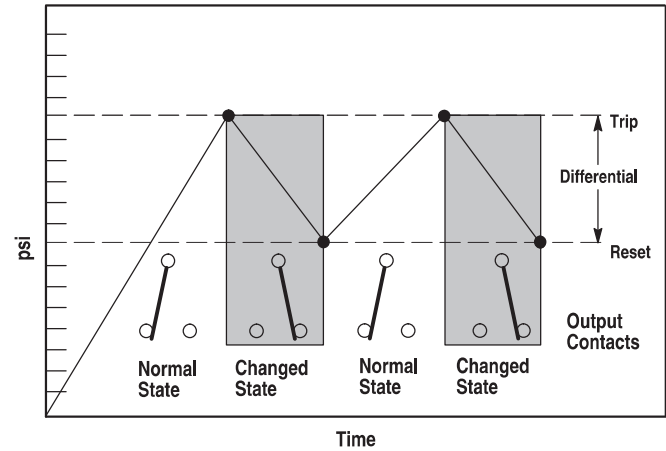
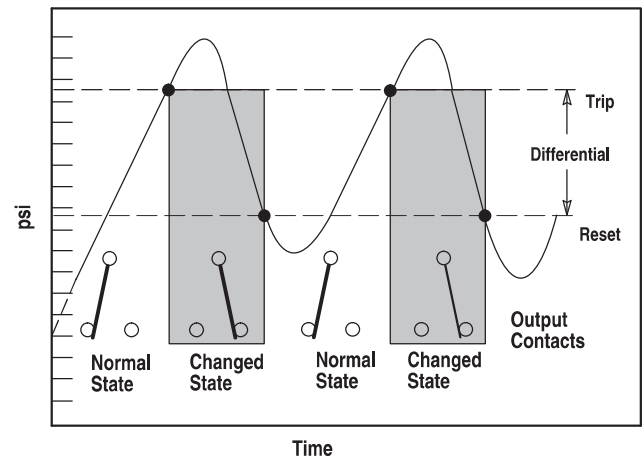

Figure 5
Typical monitoring application



Control Settings

Allen-Bradley controls are designed for ease of setting to help minimize installation time. Standard controls shipped from the factory are set at the maximum operating range and minimum differential. By following this simple two-step process, the control can be set to the specific requirements for each application. See Figure 6.

Step 1 — Adjust trip setting

The trip setting is achieved by turning the operating range adjustment screw. Turn the range screw counterclockwise to lower the trip setting, or clockwise to raise the trip setting. The approximate trip setting is shown on the indicating scale.

Note: Turning the operating range adjustment screw will change both the trip and reset settings in virtually equal increments.

Step 2 — Adjust reset setting

The reset setting is achieved by turning the differential adjustment screw counterclockwise to increase the differential, or clockwise to decrease the differential.

Note: Adjusting the differential has little or no affect upon the trip setting.

Figure 6
Trip and reset adjustment

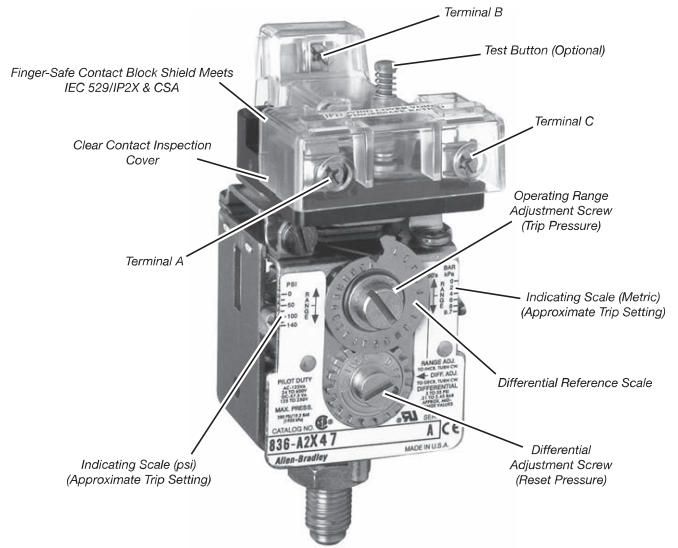

Repeat Accuracy and Mechanical Life

The design and construction of Bulletin 836 Styles A and C controls provide a typical repeat accuracy of + 0.5% or better. Repeat accuracy is based on percent of maximum range, evaluated from test data and calculated using the formula per ICS 2-225 standards.

Repeat accuracy and mechanical life of bellows type controls is graphically illustrated in Figure 7. For general applications, controls selected where the contacts operate between 30...80% of the operating range and where the maximum line and surge pressures do not exceed the specified values will provide excellent life and repeat accuracy. For more specific applications, it is important to note that the controls are designed to operate **below** or **above** these values. However, there may be a small trade-off between the factors of repeat accuracy and mechanical life.

Figure 7

Repeat accuracy versus mechanical life graph

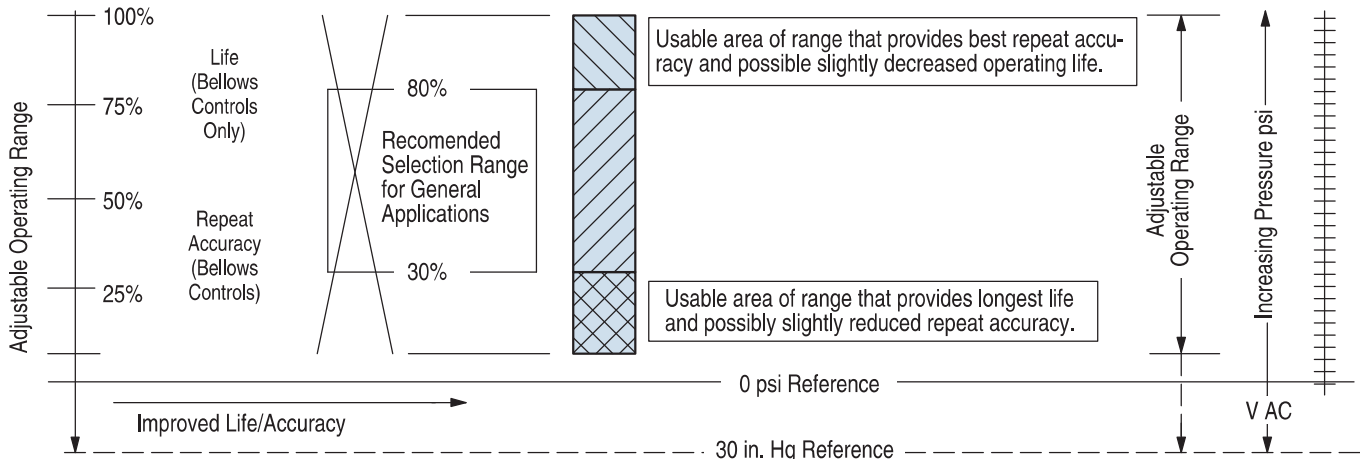

Standard Contacts

Snap-action contact operation

Contact blocks are single-pole, double-throw and can be wired to open or close on increasing or decreasing pressures.

Non-inductive ratings

5 A, 240V
3 A, 600V

Control circuit ratings

AC - 125 VA, 24...600V
DC - 57.5 VA, 115...230V

Standard Contact Wiring Configurations

Single-pole double throw

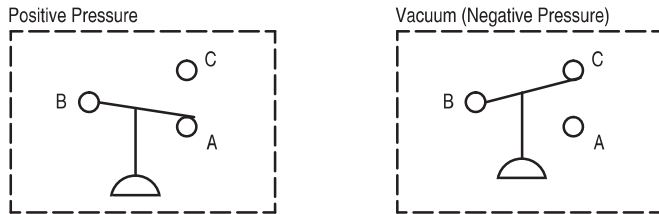

Note: NEMA does not rate contacts to switch low voltage and current.

Bulletin 836 Styles A and C Pressure Controls are supplied with silver contacts. The devices are designed to deliver high-force snap action to the contacts. This provides exceptional contact fidelity at 24V DC I/O card current level entry when the control is protected in a suitable enclosure for the surrounding environment.

Special Controls

A large number of unlisted catalog modifications and complete devices are available for specific and OEM applications.

Special controls and modification service is available to meet many applications unique to the OEM market.

Please contact your local Rockwell Automation sales office or Allen-Bradley distributor for assistance with specific modified controls and accessories.

Temperature Range

Temperature range at +32 °F (0 °C) or below is based on the absence of freezing moisture, water, or other fluids that may solidify and impede operation of the control. Temperature ratings are as follows:

- Operating: -22... +150 °F
(-30...+66 °C)
- Storage: -22...+200 °F
(-30...+93 °C)

Factory-Set Pressure Controls

Rockwell Automation will factory set pressure control values to customer-specified values only if a Cat. No. 836-C device is ordered. Catalog numbers ordered without the "C" suffix are set at the maximum operating range and minimum differential. See Factory Options.

Pressure Control Selection

The selection table below is an overview of the three types of Allen-Bradley Bulletin 836 Pressure Controls. Each type of control is suitable for use on many types of applications. Pressure ranges, pressure connections, enclosure types, and the compatibility of the actuator with different types of pressure media are given to assist in the selection of which type of control to use.

	836 Style A	836 Style C	836 Style C
Actuator Type	Internal Bellows, Copper Alloy	External Bellows, Copper Alloy	External Bellows, Stainless Steel Type 316
Adjustable Operating Ranges	30 in. Hg Vacuum...375 psi	30 in. Hg Vacuum...900 psi	30 in. Hg Vacuum...375 psi
Adjustable Differentials	2...95 psi	0.2...125 psi	0.4...80 psi
Maximum Line Pressures	up to 750 psi	up to 1300 psi	up to 650 psi
Occasional Surge Pressures	up to 850 psi	up to 1600 psi	up to 650 psi
Pressure Media			
Air	•	•	•
Water	•	•	•
Hydraulic Fluids	•	•	•
Liquids: Corrosive ★			•
Non-Corrosive	•	•	•
Gases: Corrosive ★			•
Non-Corrosive	•	•	•
Enclosures			
Open Type	•	•	•
Type 1	•	•	•
Type 4 & 13	•	•	•
Type 4X		•	•
Type 7 & 9 and 4 & 13	•	•	•
Pipe Connections			
Pressure Connection	7/16 in.-20 SAE Flare for 1/4 in. Copper Tubing	1/4 in. N.P.T.F. Internal Pipe Thread or 3/8 in. N.P.S.F. Internal Pipe connection (836-C1 and 836-C1A only)	1/4 in. N.P.T.F. Internal Pipe Thread

★ Corrosive liquids and gases compatible with Type 316 Stainless Steel.

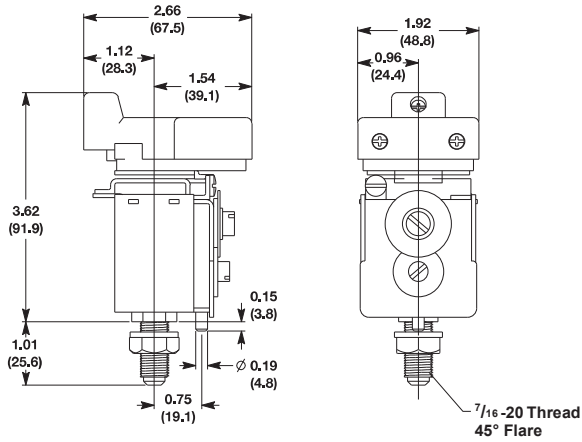

Open Type
Approximate Shipping Weight 1 lb. (0.45 kg)

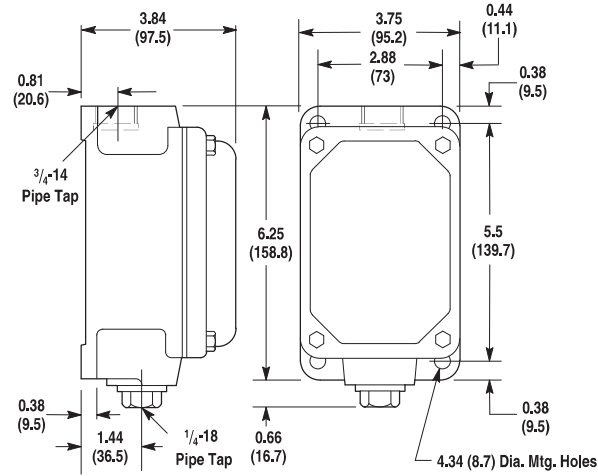

Type 7 & 9 and 4 & 13
Approximate Shipping Weight 9 lbs (4.1 kg)

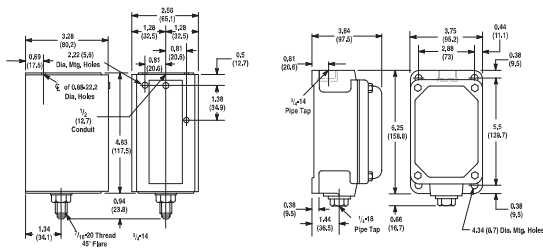

Type 1
Approximate Shipping Weight 2 lbs (0.91 kg)

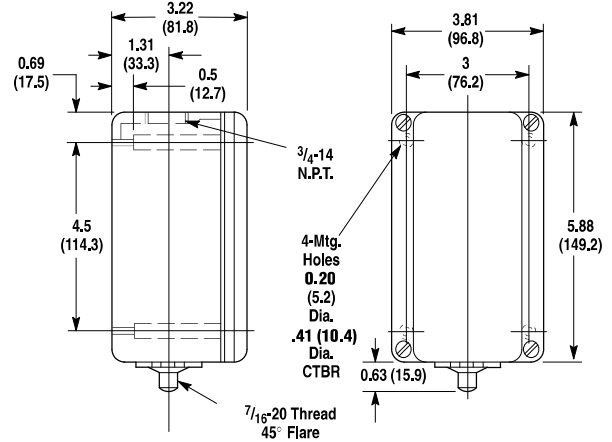

Type 4 & 13
Approximate Shipping Weight 3 lbs (1.4 kg)

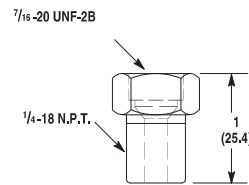

Cat. No. 836-N1
Approximate Shipping Weight 1/4 lb (0.1 kg)

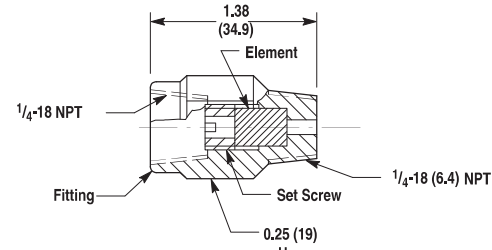

Cat. No. 836-N40
Approximate Shipping Weight 1/4 lb (0.1 kg)

Approximate Dimensions and Shipping Weights

Dimensions in inches (millimeters). Dimensions are not intended to be used for manufacturing purposes.

Style C

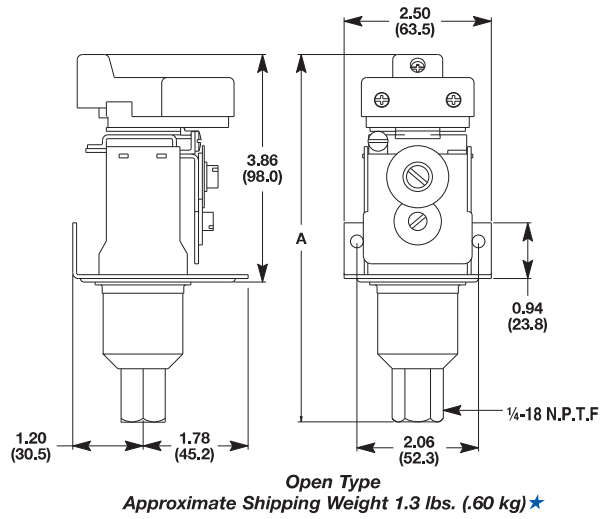

Pressure Controls

Approximate Dimensions

Approximate Dimensions and Shipping Weights

Dimensions in inches (millimeters). Dimensions are not intended to be used for manufacturing purposes.

Style A

Cat. No.	Dimension A
C2, C3, C60, C61	6.11 (155)
C4	5.99 (152)
C5, C64	5.94 (151)
C6, C62	6.29 (160)
C7, C63	6.24 (158)
C8, C9	5.56 (141)
C10, C11, C12, C65	5.78 (147)

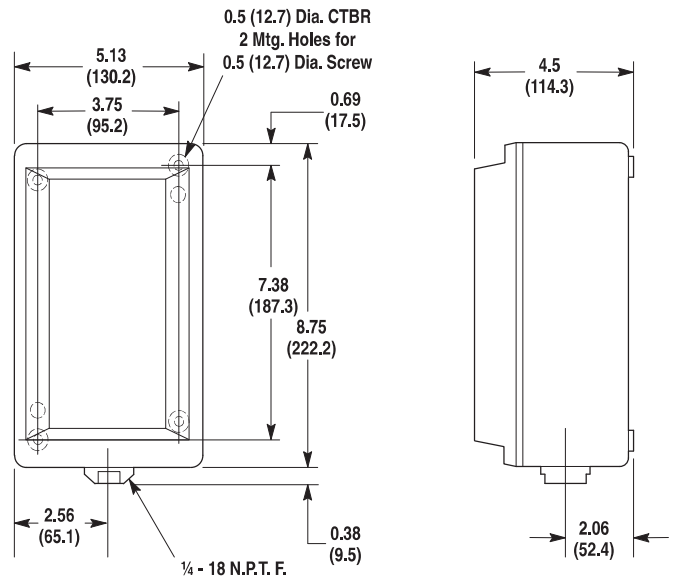
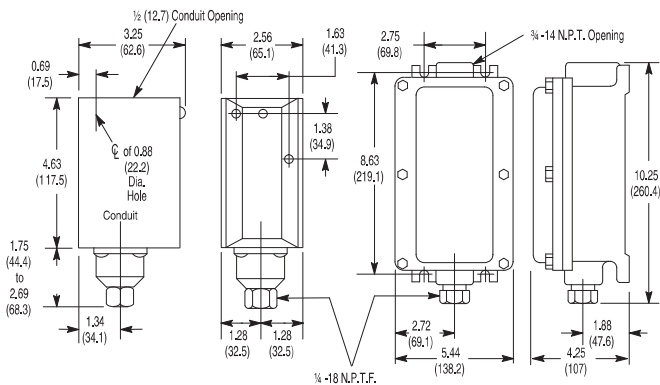
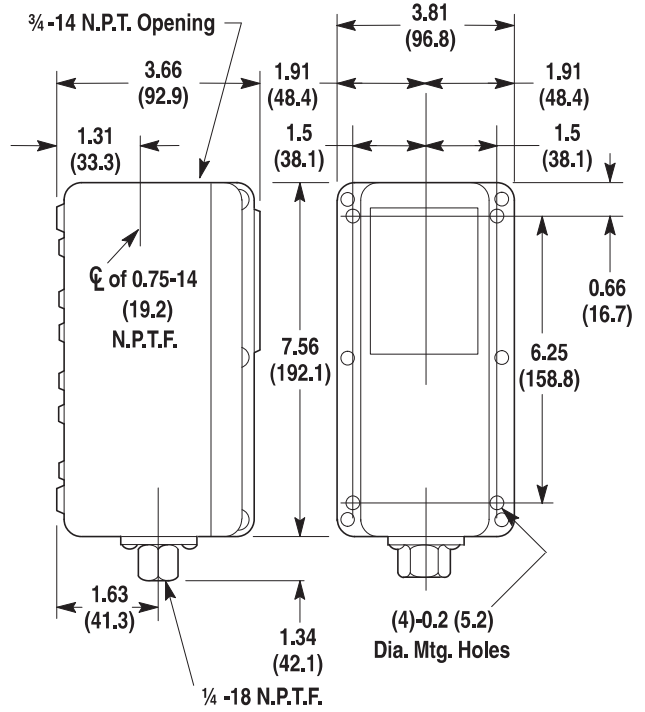

★ Cat. No.s 836-C1 and 836-C1A:
 Require a 2 in. swing radius from centerline of pressure connection. Mount control on 7/8 in. minimum spacers
 Have a 3/8-18 N.P.S.F. internal pipe connection