

700-HA Relay Performance Graphs

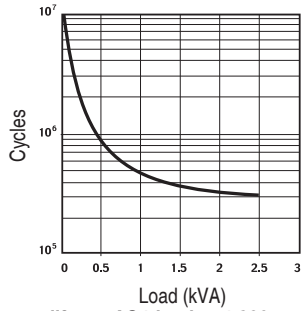

Contact life vs. AC1 load at 1,800 cycles/h

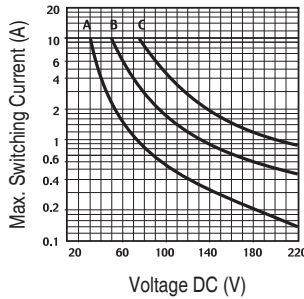

Breaking capacity for DC1 load at 1,800 cycles/h.

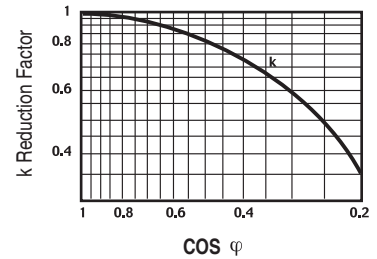

Load reduction factor vs. $\cos \phi$

A = load applied to one contact
 B = load applied to two contacts in series
 C = load applied to three contacts in series

Time Module Cat. No. 700-HT3		
Electrical Ratings		
Operating Voltage Range	12...240V AC (50/60 Hz) 12...240V DC	
Power Consumption	0.1 W (12V) 1.0 W (230V)	
Mechanical		
Degree of Protection of Input (B1) Terminal	IP 20 (Guarded Terminal)	
Input Terminal Wire Range	1.0 x 0.2 mm ² ...2.5 mm ² (24 AWG...14 AWG) 2.0 x 0.2 mm ² ...1.5 mm ² (24 AWG...16 AWG)	
Input Terminal Torque Range	0.45...0.8 Nm (4...7 lb-in.)	
LED Indicator	Red	
Repeat Accuracy‡	±1%	
Recovery Time	<50 ms	
Selectable Timing Ranges	Three DIP switches, seven ranges (set from 5...100% of range): 1 s, 10 s, 100 s, 10 min, 100 min, 10 h, 100 h	
Selectable Timing Modes	Three DIP switches, eight modes: 1. Power On-Delay 2. Power On One-Shot 3. Power On Repeat Cycle, On Start 4. Signal On-Delay and Signal Off-Delay 5. Signal Off-Delay 6. Signal On-One-Shot 7. Signal Off-One-Shot 8. Signal On and Signal Off Watchdog Monitor	
Adjustable Trimmer Scale Accuracy	±5% of Time Range	
Environmental		
Temperature	Operating	-20 °C...+50 °C (-4 °F...+122 °F)
	Storage	-55 °C...+85 °C (-67...+185 °F)
Altitude	2000 m (6560 ft)	
Construction		
Enclosure	Gray Plastic Housing	
Mounting with Socket Only	8- or 11-Pin Socket with Module Plug	
Sockets	700-HN204 (8-Pin with Plug) 700-HN205 (11-Pin with Plug)	
Certifications	cURus Recognized (File No. E14843, Guide NRNT2/NRNT8), CE Marked	
Standards	UL508, CSA C22.2 No. 14, EN 61810-1	

‡ At constant voltage and temperature.

Timing Charts, Cat. No. 700-HT3 Multi-Function Time Module (t = Time Range 0.05 s...100 h)

Terms:

- U** is Power Input
- R** is Relay Output
- S** Signal, **+A1** Socket, **B1** Timer
- t** is the resulting Time Delay (Red LED)

1. Power On-Delay

Apply power (U) to timer. Relay contacts (R) change state after time delay (t) is complete. Contacts return to their shelf state when power is removed. Terminal B1 is not used in this mode.



2. Power On One-Shot

Apply power (U) to timer. Relay contacts (R) change state immediately and the time delay begins. When the time delay (t) is complete, contacts return to their shelf state. Contacts return to their shelf state when power is removed. Terminal B1 is not used in this mode.



3. Power On Repeat Cycle, On Start

Apply power (U) to timer. Relay contacts (R) change state immediately and the time delay (t) begins. When the time delay is complete, the contacts return to their shelf state for time delay (t) (time on = time off). This cycle will repeat until the power is removed. Terminal B1 is not used in this mode.

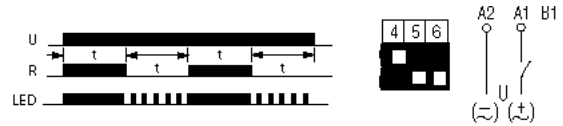

4. Signal On-Delay and Signal Off-Delay

Apply power (U) to timer. When the signal (S) is closed the time delay (t) begins, after the time delay is complete the relay contacts (R) change state. Opening the signal starts the time delay, after the time delay is complete the contacts return to their shelf state. If the signal is closed or opened before the time delay is complete, the time delay is reset. Contacts return to their shelf state when power is removed.

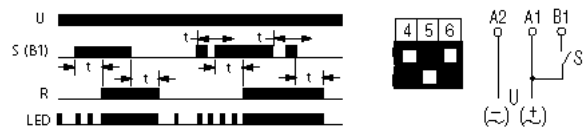

Cat. No. 700-HT3 Timing Modes, Time Description, Timing Charts, and DIP Switch Selections

5. Signal Off-Delay

Apply power (U) to timer. When the signal (S) is closed, the relay contacts (R) change state immediately. When the signal is opened, the time delay (t) begins. If the signal is closed before the time delay is complete, the time delay is reset and the relay remains energized. When the time delay is complete, the contacts return to their shelf state. Contacts return to their shelf state when power is removed.

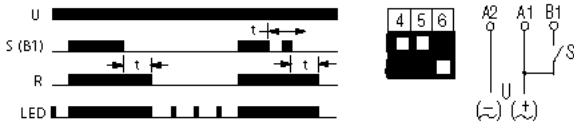

6. Signal On One-Shot

Apply power (U) to timer. When the signal (S) is closed, the relay contacts (R) change state immediately and the time delay (t) begins. After the time delay begins, opening or closing the signal will not reset the time delay. When the time delay is complete, the contacts return to their shelf state. Contacts return to their shelf state when power is removed.

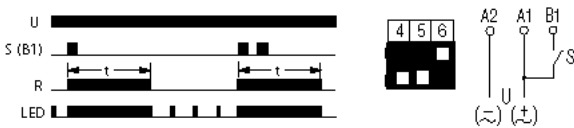

7. Signal Off One-Shot

Apply power (U) to timer. When the signal (S) is closed and then opened, the relay contacts (R) change state immediately and the time delay (t) begins. After the time delay begins, opening or closing the signal will not reset the time delay. When the time delay is complete, the contacts return to their shelf state. Contacts return to their shelf state when power is removed.

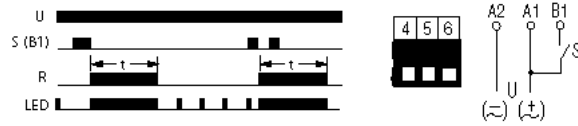

8. Signal On and Signal Off Watchdog Monitor

Apply power (U) to timer. When the signal (S) is closed, the relay contacts (R) energize immediately and the time delay (t) begins. If the signal is opened before the time delay is complete, the relay remains energized and the time delay is reset. When the time delay is complete the contacts return to their shelf state. If the signal is opened after the time delay is complete, the relay contacts energize immediately and the same time delay begins. Continuous cycling of the signal at a rate that is faster than the time delay will cause the relay contacts to remain energized. Contacts return to their shelf state when power is removed.

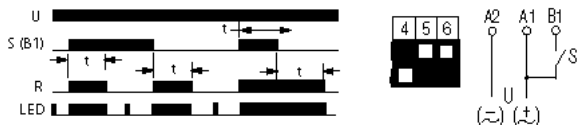

Approximate Dimensions are shown in millimeters (inches). Approximate Dimensions are not intended to be used for manufacturing purposes.

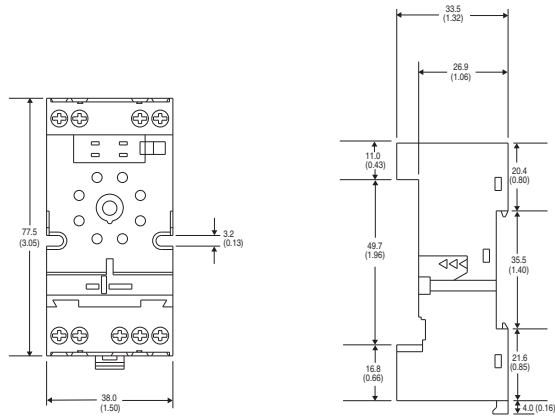

Cat. No. 700-HN204

Wire Size: $2 \times 2.5 \text{ mm}^2$
 Single Wire – Up to #12 AWG
 Double Wire – $2 \times 2.5 \text{ mm}^2$ (#2–14 AWG... #2–20 AWG)
 (Either Solid or Stranded)
 Strip Length: 9 mm (3/8 in.) – Torque: 0.8 N•m (7 lb•in)

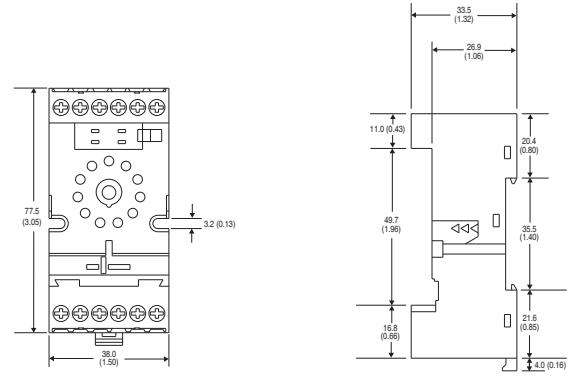

Cat. No. 700-HN205

Wire Size: $2 \times 2.5 \text{ mm}^2$
 Single Wire – Up to #12 AWG
 Double Wire – $2 \times 2.5 \text{ mm}^2$ (#2–14 AWG ... #2–20 AWG)
 (Either Solid or Stranded)
 Strip Length: 9 mm (3/8 in.) – Torque: 0.8 N•m (7 lb•in)

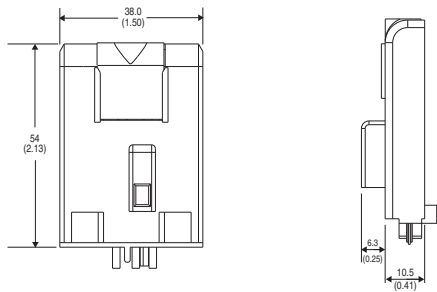

Cat. No. 700-HT3

Wire Size: $2 \times 1.5 \text{ mm}^2$ (#2 – 16 AWG... #1–20 AWG)
 (Either Solid or Stranded)
 Strip Length: 9 mm (3/8 in.) – Torque: 0.8 N•m (7 lb•in)

Approximate Dimensions

Approximate Dimensions are shown in millimeters (inches). Approximate Dimensions are not intended to be used for manufacturing purposes.

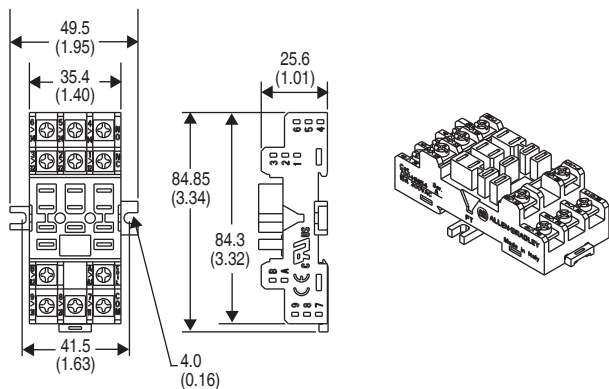

Cat. No. 700-HN154
Wire Size: 2 x 2.5 mm²
Single Wire – Up to #12 AWG
Double Wire – 2 x 2.5 mm² (#2–14 AWG... #2–20 AWG)
(Either Solid or Stranded)
Strip Length: 9 mm (3/8 in.) – Torque: 0.8 N•m (7 lb•in)

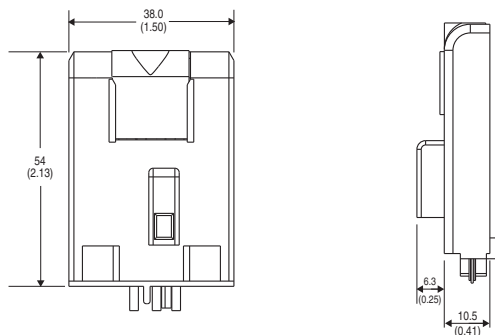

Cat. No. 700-HT3
Wire Size: 2 x 1.5 mm² (#2–16 AWG... #1–20 AWG)
(Either Solid or Stranded)
Strip Length: 9 mm (3/8 in.) – Torque: 0.8 N•m (7 lb•in)

Specifications

		Cat. No. 700-HTA...			
Electrical Ratings					
Pilot Duty Rating‡		NEMA B300 AC 15			
Rated Thermal Current (I^th)		10 A			
Rated Insulation Voltage (U _i)		250V IEC, 300V UL/CSA			
Contacts		Inductive	Make	Break	HP
			►][◄	◄][►	
		120V AC	30 A	3 A	1/3
		240V AC	15 A	1.5 A	1/2
		Resistive 30V DC	10 A	10 A	—
Permissible Coil Voltage Variation		85...110% of Nominal Voltage at 50 Hz 85...110% of Nominal Voltage at 60 Hz			
Power Consumption ±10%	AC	24V AC	2 VA		
		120V AC	4 VA		
		240V AC	4 VA		
Design Specification/Test Requirements					
Dielectric Withstand Voltage		Pole-to-Pole, same circuit (VRMS)	1000V AC		
		Pole-to-Pole, different circuits (VRMS)	2000V AC		
		Contact-to-Coil (VRMS)	2000V AC		
Electrical Life Operations		100,000 minimum			
Switching Frequency Operations		1800/hr			
Coil Voltages		See product selection			
Mechanical					
Degree of Protection		Open Type (Guarded Terminal Sockets)			
Mechanical Life Operations		10 x 10 ⁶			
Switching Frequency Operations		18,000/hr			
Start-up Time (max. time from power application until unit is timing)		0.05 sec			
Max. Function Time (max. time power can drop out and unit continues timing)		0.01 sec			
Min. Cycle Time		100 ms on release of the control switch			
Environmental					
Temperature	Operating	-28...+65 °C (50 °C max., 240V AC coil) (-18...+149 °F) (122 °F max., 240V AC coil)			
	Storage	-55...+85 °C (-67...+185 °F)			
Altitude		2000 m (6560 ft)			
Construction					
Insulating Material		Molded High Dielectric Material			
Enclosure		Impact Resistant Dust Cover			
Contact Material		Silver Tin Oxide			
Terminal Markings on Socket		In accordance with EN50 005			
Sockets		8- or 11-Pin Socket 700-HN100, -HN125 700-HN101, -HN126			
Certifications		CSA Certified, File 223833, UL Recognized (File E3125 Guide NLDX2/NLDX8), cULus Listed with 700-HN100, 700-HN101, 700-HN125, and 700-HN126 Sockets (File No. E3125 Guide NLDX/NLDX7), CE-Marked (per EU Low Voltage Directive)			
Standards		EN 61812-1, EN/IEC 60947-1, -5-1, CSA 22.2 No. 14, UL 508			

‡ NEMA Rating Chart is in publication 700-SG003_-EN-P.

Trigger Signal Cat. Nos. 700-HTA

Contact closure provides signal to timer. A low energy signal is generated by the 700-HTA alternating relay. For optimum reliability, use contacts designed for low energy switching (10V, 1 mA) (Example: Bul. 800F-X__V, 800T-X__V). No external voltage should be connected to the contact signal.

Load Diagrams

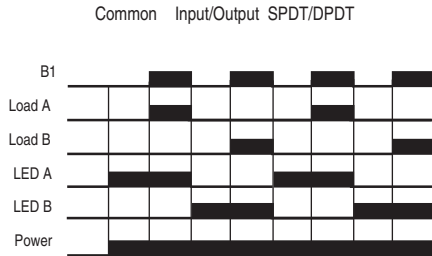

Socket Pinout Map SPDT		Socket Pinout Map DPDT	
Relay	Socket	Relay	Socket
A1	4	A1	4
A2	3	A2	8

Note: pin out in wiring diagram may not match actual printed socket see pinout map for wiring up the power source

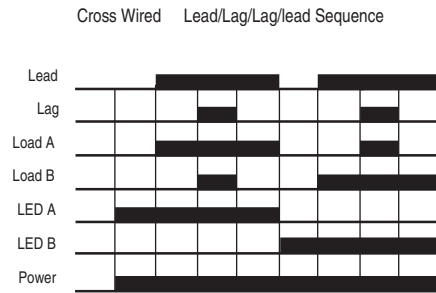

Socket Pinout Map Cross-Wired	
Relay	Socket
A1	3
A2	6

Note: pin out in wiring diagram may not match actual printed socket see pinout map for wiring up the power source

Approximate Dimensions

Approximate Dimensions are shown in millimeters (inches). Approximate Dimensions are not intended to be used for manufacturing purposes.

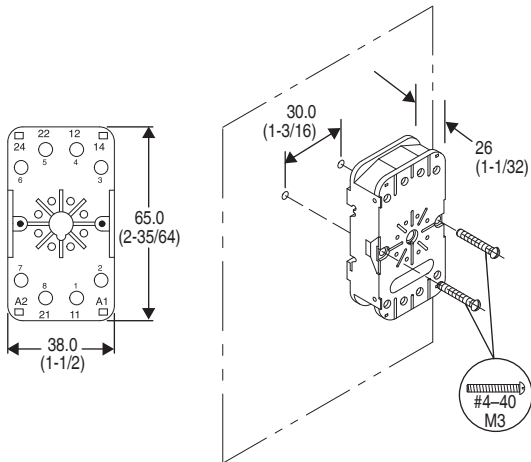
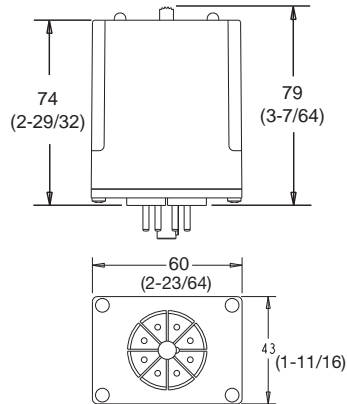

Cat. No. 700-HN100
Panel Mounting

Double Wire — 2 x 2.5 mm² (#2 – 14 AWG...#2 – 20 AWG)
 (Either Solid or Stranded)
Strip Length: 9 mm (3/8 in) – Torque: 0.8 N•m (7 lb•in)

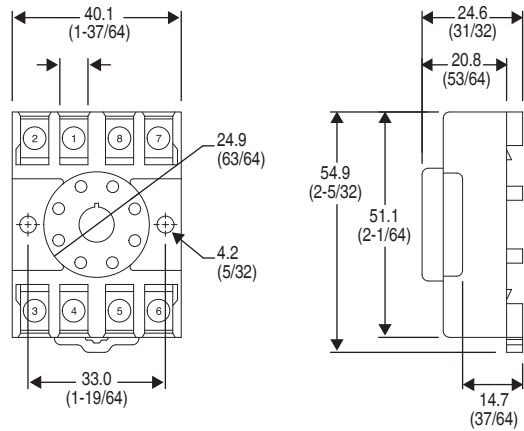

Cat. No. 700-HN125

Wire Size: 2 x 2.5 mm²
Single Wire — Up to #12 AWG
Double Wire — 2 x 2.5 mm² (#2 – 14 AWG... #2 – 20 AWG)
 (Either Solid or Stranded)
Strip Length: 9 mm (3/8 in) — Torque: 0.8 N•m (7 lb•in)

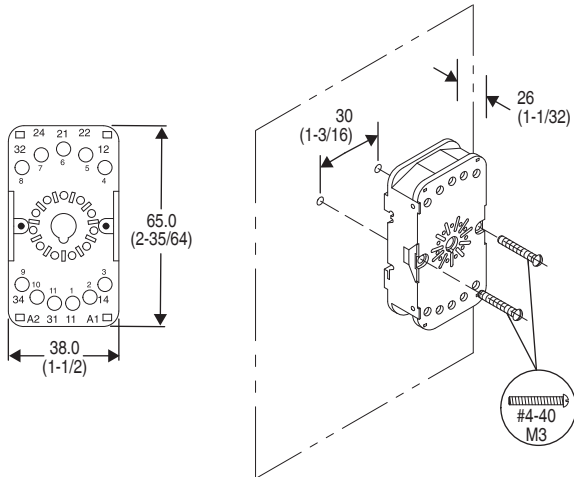

Cat. No. 700-HN101
Panel Mounting

Double Wire – 2 x 2.5 mm² (#2 – 14 AWG...#2 – 20 AWG)
(Either Solid or Stranded)
Strip Length: 9 mm (3/8 in) – **Torque:** 0.8 N•m (7 lb•in)

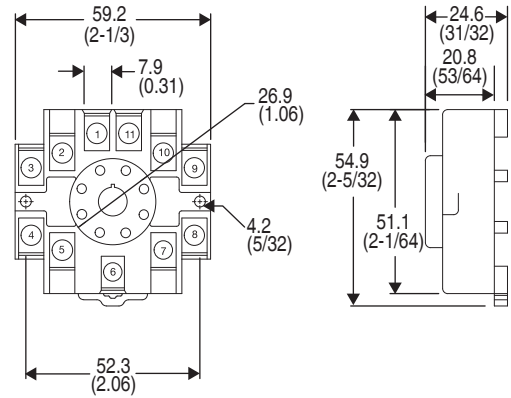

Cat. No. 700-HN126

Wire Size: 2 x 2.5 mm²
Single Wire — Up to 12 AWG
Double Wire — 2 x 2.5 mm² (#2 – 14 AWG...#2 – 20 AWG)
(Either Solid or Stranded)
Strip Length: 9 mm (3/8 in) — **Torque:** 0.8 N•m (7 lb•in)