

## Available 1769 I/O Modules

I/O Type	Cat. No.	Page	Cat. No.	Page
AC digital	<a href="#">1769-IA8I</a>	<a href="#">6</a>	<a href="#">1769-OA8</a>	<a href="#">57</a>
	<a href="#">1769-IA16</a>	<a href="#">8</a>	<a href="#">1769-OA16</a>	<a href="#">60</a>
	<a href="#">1769-IM12</a>	<a href="#">35</a>		
DC digital	<a href="#">1769-IG16</a>	<a href="#">33</a>	<a href="#">1769-OB8</a>	<a href="#">63</a>
	<a href="#">1769-IQ16</a>	<a href="#">37</a>	<a href="#">1769-OB16</a>	<a href="#">64</a>
	<a href="#">1769-IQ16F</a>	<a href="#">39</a>	<a href="#">1769-OB16P</a>	<a href="#">67</a>
	<a href="#">1769-IQ32</a>	<a href="#">41</a>	<a href="#">1769-OB32</a>	<a href="#">69</a>
	<a href="#">1769-IQ32T</a>	<a href="#">43</a>	<a href="#">1769-OB32T</a>	<a href="#">72</a>
	<a href="#">1769-IQ6XOW4</a>	<a href="#">45</a>	<a href="#">1769-OG16</a>	<a href="#">90</a>
			<a href="#">1769-OV16</a>	<a href="#">92</a>
		<a href="#">1769-OV32T</a>	<a href="#">94</a>	
Contact	<a href="#">1769-OW8</a>	<a href="#">96</a>	<a href="#">1769-OW16</a>	<a href="#">100</a>
	<a href="#">1769-OW8I</a>	<a href="#">98</a>		
Analog	<a href="#">1769-IF4</a>	<a href="#">10</a>	<a href="#">1769-OF2</a>	<a href="#">74</a>
	<a href="#">1769-IF4I</a>	<a href="#">13</a>	<a href="#">1769-OF4</a>	<a href="#">76</a>
	<a href="#">1769-IF4XOF2</a>	<a href="#">16</a>	<a href="#">1769-OF4CI</a>	<a href="#">79</a>
	<a href="#">1769-IF4FXOF2F</a>	<a href="#">19</a>	<a href="#">1769-OF4VI</a>	<a href="#">82</a>
	<a href="#">1769-IF8</a>	<a href="#">24</a>	<a href="#">1769-OF8C</a>	<a href="#">85</a>
	<a href="#">1769-IF16C</a>	<a href="#">28</a>	<a href="#">1769-OF8V</a>	<a href="#">87</a>
	<a href="#">1769-IF16V</a>	<a href="#">30</a>		
	<a href="#">1769-IR6</a>	<a href="#">48</a>		
	<a href="#">1769-IT6</a>	<a href="#">53</a>		
Specialty	<a href="#">1769-ARM</a>	<a href="#">102</a>	<a href="#">1769-BOOLEAN</a>	<a href="#">105</a>
	<a href="#">1769-ASCII</a>	<a href="#">103</a>	<a href="#">1769-HSC</a>	<a href="#">109</a>

**Table 1 - Environmental Specifications - 1769 I/O Modules**

Attribute	1769-IA8I, 1769-IA16, 1769-IM12, 1769-OA8, 1769-OA16, 1769-IQ16, 1769-IQ16F, 1769-IQ32, 1769-IQ6XOW4, 1769-OB8, 1769-OB16, 1769-OB16P, 1769-OB32, 1769-OV16, 1769-OW8, 1769-OW8I, 1769-OW16 1769-IF4, 1769-IF4XOF2, 1769-IR6, 1769-IT6 1769-ARM, 1756-HSC	1769-IG16, 1769-IQ32T, 1769-OB32T, 1769-OG16, 1769-OV32T 1769-IF4I, 1769-IF8, 1769-IF16C, 1769-IF16V, 1769-OF2, 1769-OF4CI, 1769-OF4VI, 1769-OF8C, 1769-OF8V, 1769-IF4FXOF2F 1769-ASCII, 1769-BOOLEAN
Temperature, operating IEC 60068-2-1 (Test Ad, Operating Cold), IEC 60068-2-2 (Test Bd, Operating Dry Heat), IEC 60068-2-14 (Test Nb, Operating Thermal Shock)	0...60 °C (32...140 °F)	0...60 °C (32...140 °F)
Temperature, storage IEC 60068-2-1 (Test Ab, Unpackaged Nonoperating Cold), IEC 60068-2-2 (Test Bb, Unpackaged Nonoperating Dry Heat), IEC 60068-2-14 (Test Na, Unpackaged Nonoperating Thermal Shock)	-40...85 °C (-40...185 °F)	-40...85 °C (-40...185 °F)
Relative humidity IEC 60068-2-30 (Test Db, Unpackaged Nonoperating Damp Heat)	5...95% noncondensing	5...95% noncondensing
Vibration IEC 60068-2-6 (Test Fc, Operating)	Operating: 5 g @ 10...500 Hz Relay operating: 2 g	5 g @ 10...500 Hz
Shock, operating IEC 60068-2-27 (Test Ea, Unpackaged Shock)	Panel mount 30 g DIN rail mount 20 g	Panel mount 30 g DIN rail mount 20 g
Shock, relay operating IEC 60068-2-27 (Test Ea, Unpackaged Shock)	Panel mount 7.5 g DIN rail mount 5 g	—
Shock, nonoperating IEC 60068-2-27 (Test Ea, Unpackaged Shock)	Panel mount 40 g DIN rail mount 30 g	Panel mount 40 g DIN rail mount 30 g

# 1769-OB32T

Compact solid-state 24V DC source, terminated output module

Simplified Output Circuit Diagram

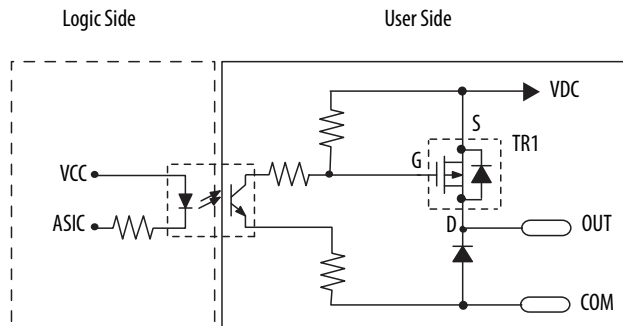

1769-OB32T

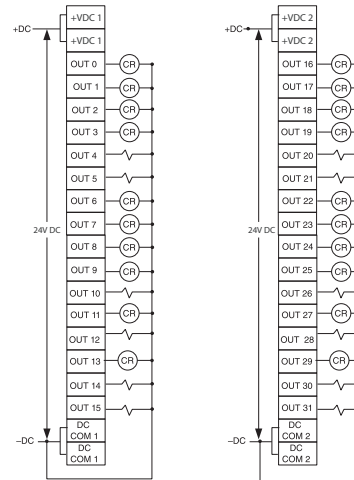

Table 71 - Technical Specifications - 1769-OB32T

Attribute	1769-OB32T
Outputs	32 terminated (16 points/group)
Voltage category	24V DC source
Operating voltage range	10.2...26.4V DC
Output delay, on	0.5 ms
Output delay, off	4.0 ms
Current draw @ 5.1V	220 mA
Heat dissipation, max	4.76 W
Off-state leakage current, max <sup>(1)</sup>	0.1 mA @ 26.4V DC
On-state current, min	1.0 mA
On-state voltage drop, max	0.3V DC @ 0.5 A
Current per point, max	0.5 A
Current per module, max	4.0 A
Surge current <sup>(2)</sup>	2.0 A for 10 ms, repeatable every 2 s
Isolation voltage	Verified by one of the following dielectric tests: 1200V AC for 2 s or 1697V DC for 2 s, output point to bus 75V DC working voltage (IEC Class 2 reinforced insulation)
Weight, approx	230 g (0.51 lb)
Dimensions (HxWxD), approx	118 x 35 x 87 mm (4.65 x 1.38 x 3.43 in.) Height with mounting tabs 138 mm (5.43 in.)
Slot width	1
Module location	DIN rail or panel mount
Power supply	1769-PA2, 1769-PB2, 1769-PA4, 1769-PB4
Power supply distance rating	8 modules
Terminal screw torque	0.68 N•m (6 lb•in)
Retaining screw torque	0.46 N•m (4.1 lb•in)

**Table 71 - Technical Specifications - 1769-OB32T**

Attribute	1769-OB32T
Wire size	(22...14 AWG) solid (22...16 AWG) stranded
Wire type	Cu-90 °C (194 °F)
Replacement connector	1746-N3 (1 connector, 40 terminals)
Vendor ID code	1
Product type code	7
Product code	79
Enclosure type rating	None (open style)

- (1) To limit the effects of leakage current through solid-state outputs, a loading resistor can be connected in parallel with your load. Use a 5.6 k $\Omega$ , 1/2 W resistor for transistor outputs, 24V DC operation.  
(2) Use a 1N4004 diode reverse-wired across the load for transistor outputs switching 24V DC inductive loads.

**Table 72 - Certifications - 1769-OB32T**

Certification <sup>(1)</sup>	1769-OB32T
c-UL	C-UL certified (under CSA C22.2 No. 142) UL 508 listed Class I, Division 2 Group A,B,C,D Hazardous Locations (UL 1604, C-UL under CSA C22.2 No. 213)
CE	CE compliant for all applicable directives
C-Tick	C-Tick compliant for all applicable directives Australian Radiocommunications Act, compliant with: <ul style="list-style-type: none"> <li>AS/NZS CISPR 11; Industrial Enclosure</li> </ul>

- (1) When marked. See the Product Certification link at <http://www.rockwellautomation.com/global/certification/overview.page> for Declarations of Conformity, Certificates, and other certification details.