

FIGURE A

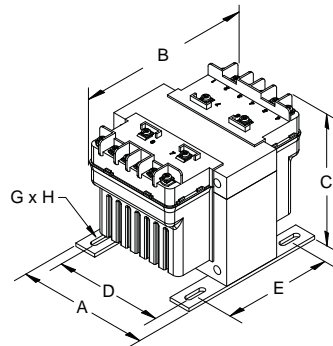

FIGURE B

## Group C

Primary Voltage: **240 X 480** || 230 X 460 || 220 X 440  
 Secondary Voltage: **120 X 240** || 115 X 230 || 110 X 220



50/60 Hertz

VA Rating	Catalog Number	Mtg. Fig.	Output Amps	Overall Dimensions			Mounting Centers		Mounting Slot G X H	Height with Finger Guard	Depth with Finger Guard	Approx. Ship Weight Lbs.	Optional Primary Fuse Kit P/N	Optional Unfused and Fused Finger Guard Kit P/N
				A	B	C	D	E						
50	PH50QMJ	A	0.42/0.21	3.00	4.38	3.19	2.50	2.25	0.22 x 0.44	4.00	5.82	3.50	PFK1	FG1*/FGF1
75	PH75QMJ	A	0.63/0.31	3.25	3.88	3.56	2.63	2.50	0.22 x 0.44	4.37	5.32	3.54	PFK1	FG2*/FGF2
100	PH100QMJ	A	0.83/0.42	3.25	4.19	3.63	2.63	2.63	0.22 x 0.44	4.50	5.63	4.50	PFK1	FG2*/FGF2
150	PH150QMJ	B	1.25/0.63	4.00	4.94	3.81	3.38	2.75	0.22 x 0.75	4.50	6.44	5.70	PFK2	FG3
250	PH250QMJ	B	2.08/1.04	4.50	5.44	3.81	3.75	3.13	0.22 x 0.75	4.50	6.94	7.50	PFK2	FG3
350	PH350QMJ	B	2.92/1.46	4.50	5.19	4.44	3.75	3.75	0.22 x 0.75	5.18	6.69	10.1	PFK3	FG4
500	PH500QMJ	B	4.17/2.08	4.75	5.94	4.31	4.06	3.81	0.31 x 0.94	5.13	7.44	14.2	PFK3	FG4
750	PH750QMJ	B	6.25/3.13	5.13	6.69	4.31	4.38	4.31	0.31 x 0.81	5.13	8.19	16.6	PFK3	FG4
1000	PH1000QMJ	B	8.33/4.17	5.25	6.81	4.94	4.50	4.44	0.31 x 0.81	5.56	8.31	23.6	PFK3	FG5
1500	PH1500QMJ	B	12.5/6.25	5.25	8.19	4.94	4.50	6.06	0.38 x 1.00	5.56	9.69	32.0	PFK3	FG5

Secondary fuse clips, fuse clip mounting screws and primary and secondary voltage links/jumpers supplied standard with transformers.

All dimensions in inches

\*Note: Unfused finger guard kits are marked with an asterisk, for more information refer to page 43.

Refer to page 64 for wiring schematic drawing. Custom voltages and VA sizes available upon request.

\*\*\* Available with FACTORY INSTALLED Primary and Secondary Fuse Kits up to 1500VA. To order, add the suffix "-FK" to the above part number. Refer to page 42 for details. \*\*\*

## Group D

Primary Voltage: **240 X 480** || 230 X 460 || 220 X 440  
 Secondary Voltage: **12 X 24** || 11.5 X 23 || 11 X 22



50/60 Hertz

VA Rating	Catalog Number	Mtg. Fig.	Output Amps	Overall Dimensions			Mounting Centers		Mounting Slot G X H	Height with Finger Guard	Depth with Finger Guard	Approx. Ship Weight Lbs.	Optional Primary Fuse Kit P/N	Optional Unfused and Fused Finger Guard Kit P/N
				A	B	C	D	E						
50	PH50QR	A	4.17/2.08	3.00	4.38	3.19	2.50	2.25	0.22 x 0.44	4.00	5.82	3.50	PFK1	FG1*/FGF1
75	PH75QR	A	6.25/3.13	3.25	3.88	3.56	2.63	2.50	0.22 x 0.44	4.37	5.32	3.54	PFK1	FG2*/FGF2
100	PH100QR	A	8.33/4.17	3.25	4.19	3.63	2.63	2.63	0.22 x 0.44	4.50	5.63	4.50	PFK1	FG2*/FGF2
150	PH150QR	B	12.5/6.25	4.00	4.94	3.81	3.38	2.75	0.22 x 0.75	4.50	6.44	5.70	PFK2	FG3
250	PH250QR	B	20.8/10.4	4.50	5.44	3.81	3.75	3.13	0.22 x 0.75	4.50	6.94	7.50	PFK2	FG3
350	PH350QR	B	29.2/14.6	4.50	5.19	4.44	3.75	3.75	0.22 x 0.75	5.18	6.69	10.1	PFK3	FG4
500	PH500QR	B	41.7/20.8	4.75	5.94	4.31	4.06	3.81	0.31 x 0.94	5.13	7.44	14.2	PFK3	FG4

Secondary fuse clips, fuse clip mounting screws and primary and secondary voltage links/jumpers supplied standard with transformers.

All dimensions in inches

\*Note: Unfused finger guard kits are marked with an asterisk, for more information refer to page 43.

Refer to page 65 for wiring schematic drawing. Custom voltages and VA sizes available upon request.